

RLM Plug Fans

Issue 4.0 EN
January 2013

AIRTREND Ltd.
Predstavništvo u Beogradu
Kumanovska 14
11000 Beograd
Tel: 011 3836886, 3085740
Faks: 011 3444113
e-mail: gobrid@eunet.rs
web: www.airtrend.rs

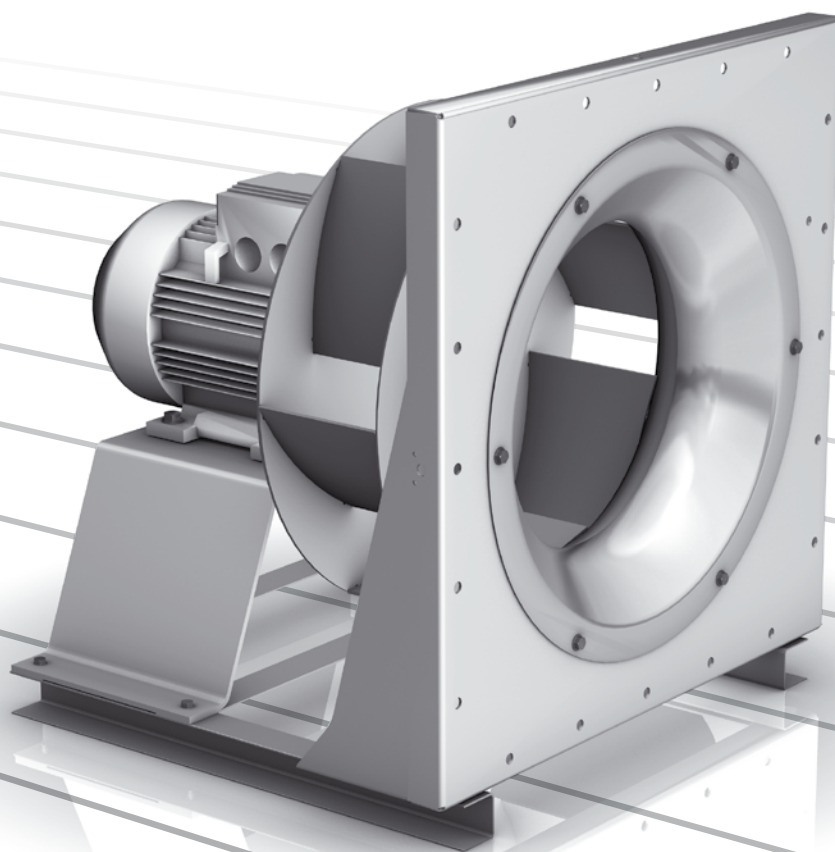

NICOTRA | **Gebhardt**
fan|tastic solutions

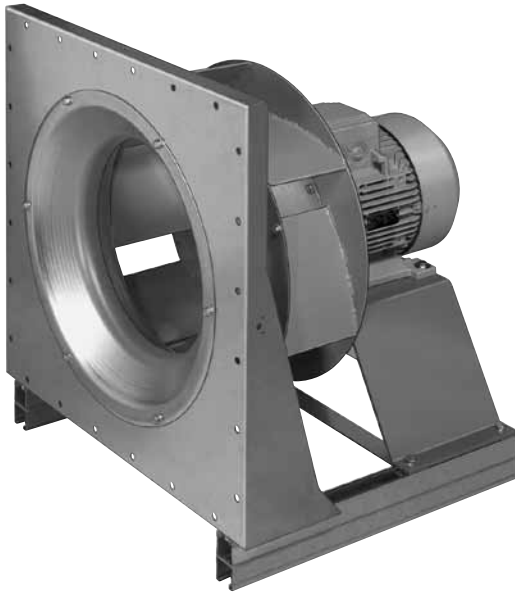

Direct drive in tolerance class 1:

Range RLM

Nicotra Gebhardt has successfully further improved its free running impeller line (plug fans).

By optimising the impeller geometry a significant reduction in noise level up to -6dB was achieved, without affecting the aerodynamic performance characteristics in any way.

In stating the performance data we have kept to the representation of the static pressure and static impeller efficiency. These values correspond to the practical figures in application case.

The fans can simply be selected via the fan selection program proSELECTA II.

All technical specifications, dimensions and performance curves are available for you.

Top quality for performance and a long service life!

The RLM advantages:

- Optimised aerodynamically and acoustically executions
- Pressure increase of 2,000Pa can be reached in the optimum range
- Optimum motor utilisation thanks to adapted impeller strength
- Short manufactured length, compact module
- Low impeller weight reduces load on the motor bearings
- Precise flow measuring device Standard

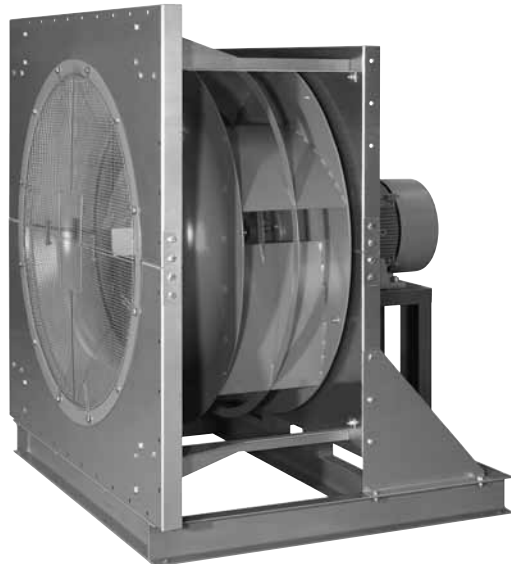

Performance data		Deviations per tolerance class		
		1	2	3
Volume flow	q_V	2.5 %	5 %	10 %
Pressure increase	p_F	2.5 %	5 %	10 %
Power consumption	P	+3 %	+8 %	+16 %
Efficiency	η	-2 %	-5 %	-
Sound power level (A weighted)	L_{WA}	+3 dB	+4 dB	+6 dB

Nicotra Gebhardt is setting accents:

RLM series!



Nicotra Gebhardt remains true to its strategy and is thus able to introduce new trends in the free running impeller range.

RLM series

- Impeller diameter 0280 up to 1400 mm nominal size
- Optimised for use without scroll
- Motor with three PTC resistors, suitable for operation at frequency inverter
- Centrifugal impeller with 6 backward curved steelblades, welded and coated
- Volume up to 100,000m³/h
- Pressure up to 2,000Pa

The RLM range of models:

The right fan for your air handling unit!

Version	Description	Figure
RLM 56-2528/-1011	Motor impeller with inlet cone, supporting plate, motor base and frame manufactured as a module and adjusted. Power data in precision class 1 according to DIN 24166.	
RLM 55-1112/-1214	Motor impeller with inlet cone, supporting plate, motor base and robust base-frame manufactured as a module and adjusted. Power data in precision class 1 according to DIN 24166.	

Technical Data

Impeller Data

Impeller diameter	D_r	288 mm
Number of blades	z	6
Moment of Inertia	J	0.034 kgm ²

Impeller Data

Impeller weight	m	3.3 kg
Density of media	ρ_1	1.2 kg/m ³
Tolerance class (DIN 24166)		1

Technical Data

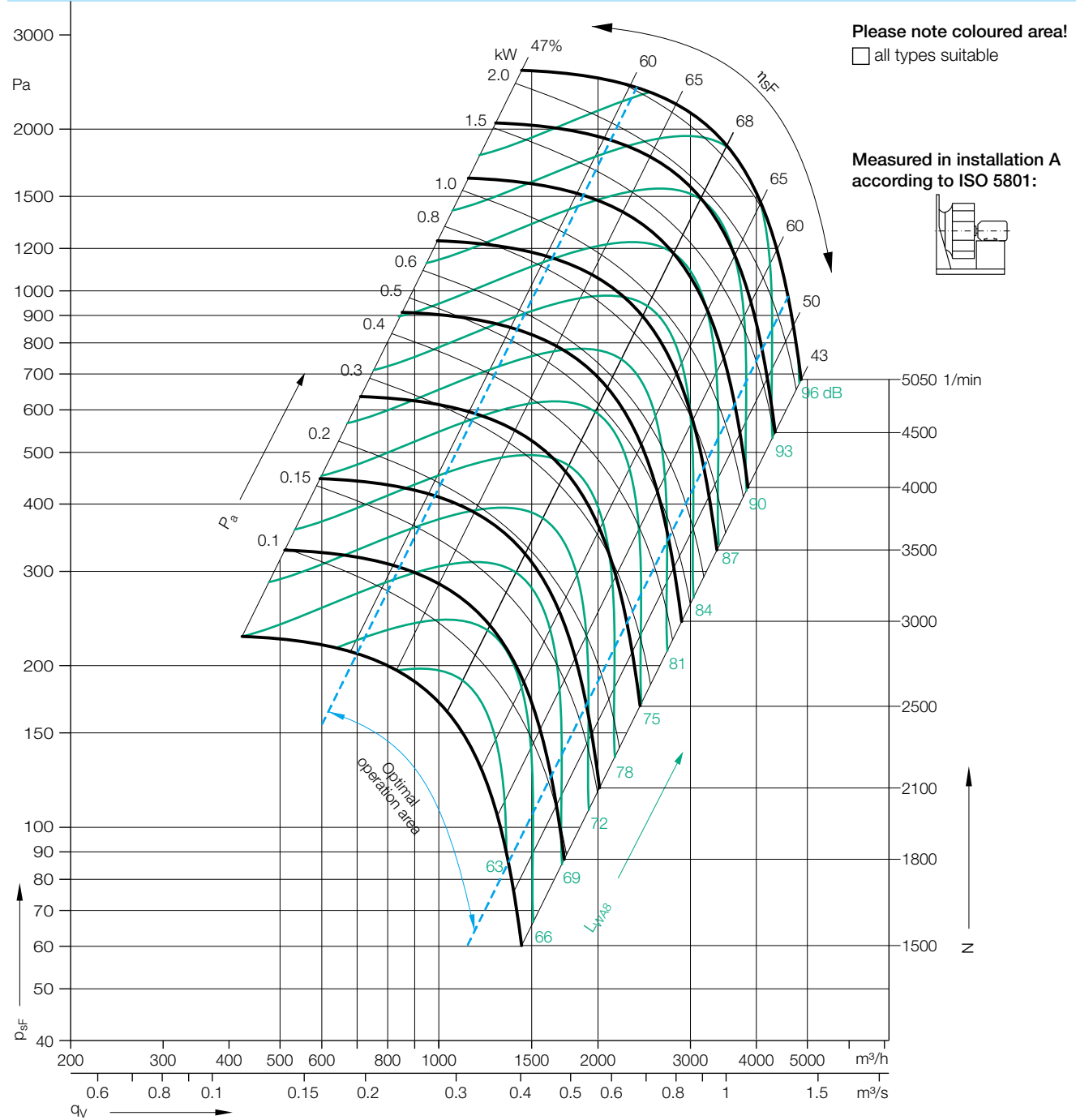

Relative sound power level for discharge side L_{wrel8} at octave centre frequencies f_m

Relative sound power level for inlet side L_{wrel5} at octave centre frequencies f_m

Speed
≤3550 1/min
Speed
>3550 1/min

63	125	250	500	1000	2000	4000	8000	Hz
-10	-11	-3	-8	-4	-7	-9	-16	dB
63	125	250	500	1000	2000	4000	8000	Hz
-10	-12	-9	-6	-5	-7	-9	-11	dB

63	125	250	500	1000	2000	4000	8000	Hz
-9	-10	1	-3	-6	-12	-14	-19	dB
63	125	250	500	1000	2000	4000	8000	Hz
-9	-11	-4	0	-6	-11	-12	-14	dB

RLM ..-2528

Technical Data

	Nominal motor power kW	Poles -	Motor size	Motor voltage V	Nominal frequency Hz	Connection	Nominal motor current A	Nominal motor speed 1/min	Max. fan speed 1/min	Max. operating frequency Hz	Weight kg
RLM 56-											
2528-2D-08	0.55	2	71 M	230/400	50	Δ/Y	2.37/1.36	2800	2980	53	21
2528-2D-10	0.75	2	80 M	230/400	50	Δ/Y	3.05/1.75	2855	3300	58	23
2528-2D-11	1.10	2	80 M	230/400	50	Δ/Y	4.25/2.45	2845	3700	65	25
2528-2D-13	1.50	2	90 S	230/400	50	Δ/Y	5.70/3.30	2860	4100	72	28
2528-2D-14	2.20	2	90 L	230/400	50	Δ/Y	8.10/4.70	2880	4600	80	31
2528-2D-16	3.00	2	100 L	400	50	Δ	6.10	2835	5050	89	35

Technical Data

	Nominal motor power kW	Poles -	Motor size	Motor voltage V	Nominal frequency Hz	Connection	Nominal motor current A	Nominal motor speed 1/min	Max. fan speed 1/min	Max. operating frequency Hz	Weight kg
RLM 56-Ex II 2G c IIB T4											
2528-2Y-08-2G	0.55	2	71 M	230/400	50	Δ/Y	2.40/1.38	2790	2970	53	35
2528-2Y-10-2G	0.75	2	80 M	230/400	50	Δ/Y	3.00/1.75	2840	3280	57	38
2528-2Y-11-2G	1.10	2	80 M	230/400	50	Δ/Y	4.30/2.45	2835	3700	65	40
2528-2Y-14-2G	1.50	2	90 S	230/400	50	Δ/Y	5.70/3.30	2850	4100	72	47
2528-2Y-15-2G	2.20	2	90 L	230/400	50	Δ/Y	8.00/4.60	2860	4600	80	50
2528-2Y-16-2G	3.00	2	100 L	400	50	Δ	6.20	2885	5050	87	59

Dimensions in mm, subject to change.

RLM 56-2528

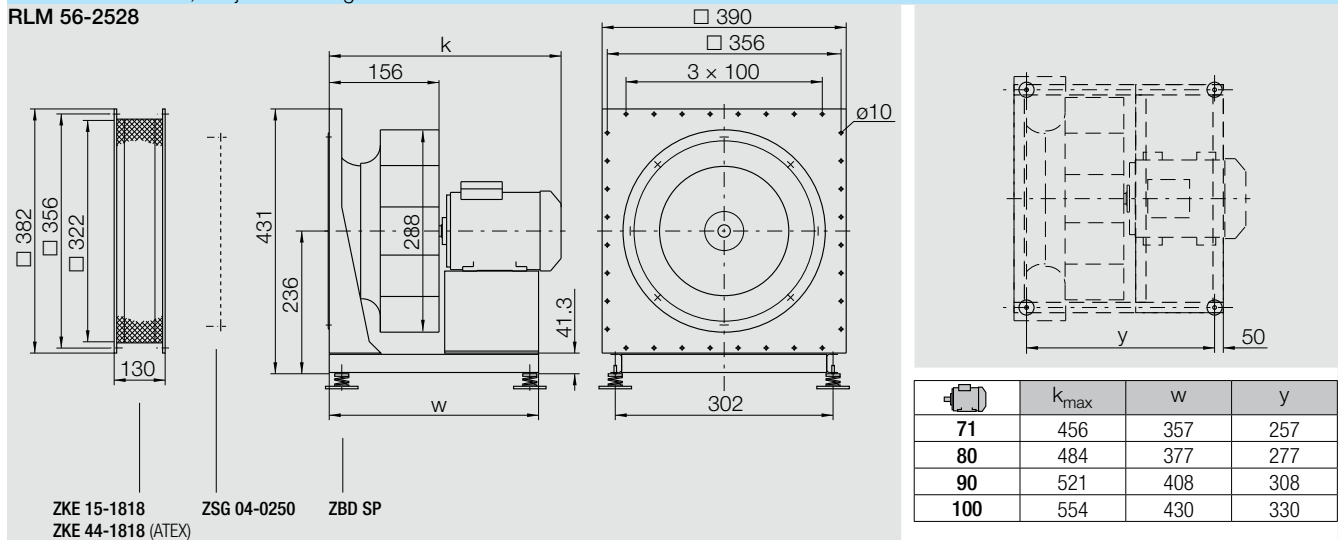

Accessories

	Frequency Inverter Unit MM420 for 3~	Frequency Inverter Unit G110 for 1~	Line Choke for 3~	Line Choke for 1~
RLM 56-				
2528-2D-08	MM420 3AC 400V 0.55KW EMV B	G110 1AC 230V 0.55KW EMV B	6SE6400-3CC00-2AD3	6SE6400-3CC01-0AB3
2528-2D-10	MM420 3AC 400V 0.75KW EMV B	G110 1AC 230V 0.75KW EMV B	6SE6400-3CC00-4AD3	6SE6400-3CC01-0AB3
2528-2D-11	MM420 3AC 400V 1.10KW EMV B	G110 1AC 230V 1.10KW EMV B	6SE6400-3CC00-4AD3	6SE6400-3CC02-6BB3
2528-2D-13	MM420 3AC 400V 1.50KW EMV B	G110 1AC 230V 1.50KW EMV B	6SE6400-3CC00-6AD3	6SE6400-3CC02-6BB3
2528-2D-14	MM420 3AC 400V 2.20KW EMV B	G110 1AC 230V 2.20KW EMV B	6SE6400-3CC01-0BD3	6SE6400-3CC02-6BB3
2528-2D-16	MM420 3AC 400V 3.00KW EMV B	-	6SE6400-3CC01-0BD3	-
RLM 56-Ex II 2G c IIB T4				
2528-2Y-08-2G	MM420 3AC 400V 0.55KW EMV B	G110 1AC 230V 0.55KW EMV B	6SE6400-3CC00-2AD3	6SE6400-3CC01-0AB3
2528-2Y-10-2G	MM420 3AC 400V 0.75KW EMV B	G110 1AC 230V 0.75KW EMV B	6SE6400-3CC00-4AD3	6SE6400-3CC01-0AB3
2528-2Y-11-2G	MM420 3AC 400V 1.10KW EMV B	G110 1AC 230V 1.10KW EMV B	6SE6400-3CC00-4AD3	6SE6400-3CC02-6BB3
2528-2Y-14-2G	MM420 3AC 400V 1.50KW EMV B	G110 1AC 230V 1.50KW EMV B	6SE6400-3CC00-6AD3	6SE6400-3CC02-6BB3
2528-2Y-15-2G	MM420 3AC 400V 2.20KW EMV B	G110 1AC 230V 2.20KW EMV B	6SE6400-3CC01-0BD3	6SE6400-3CC02-6BB3
2528-2Y-16-2G	MM420 3AC 400V 3.00KW EMV B	-	6SE6400-3CC01-0BD3	-

RLM ..-2831

Technical Data

Impeller Data

Impeller diameter	D_r	323	mm
Number of blades	z	6	
Moment of Inertia	J	0.053	kgm ²

Impeller Data

Impeller weight	m	3.9	kg
Density of media	ρ_1	1.2	kg/m ³
Tolerance class (DIN 24166)		1	

Technical Data

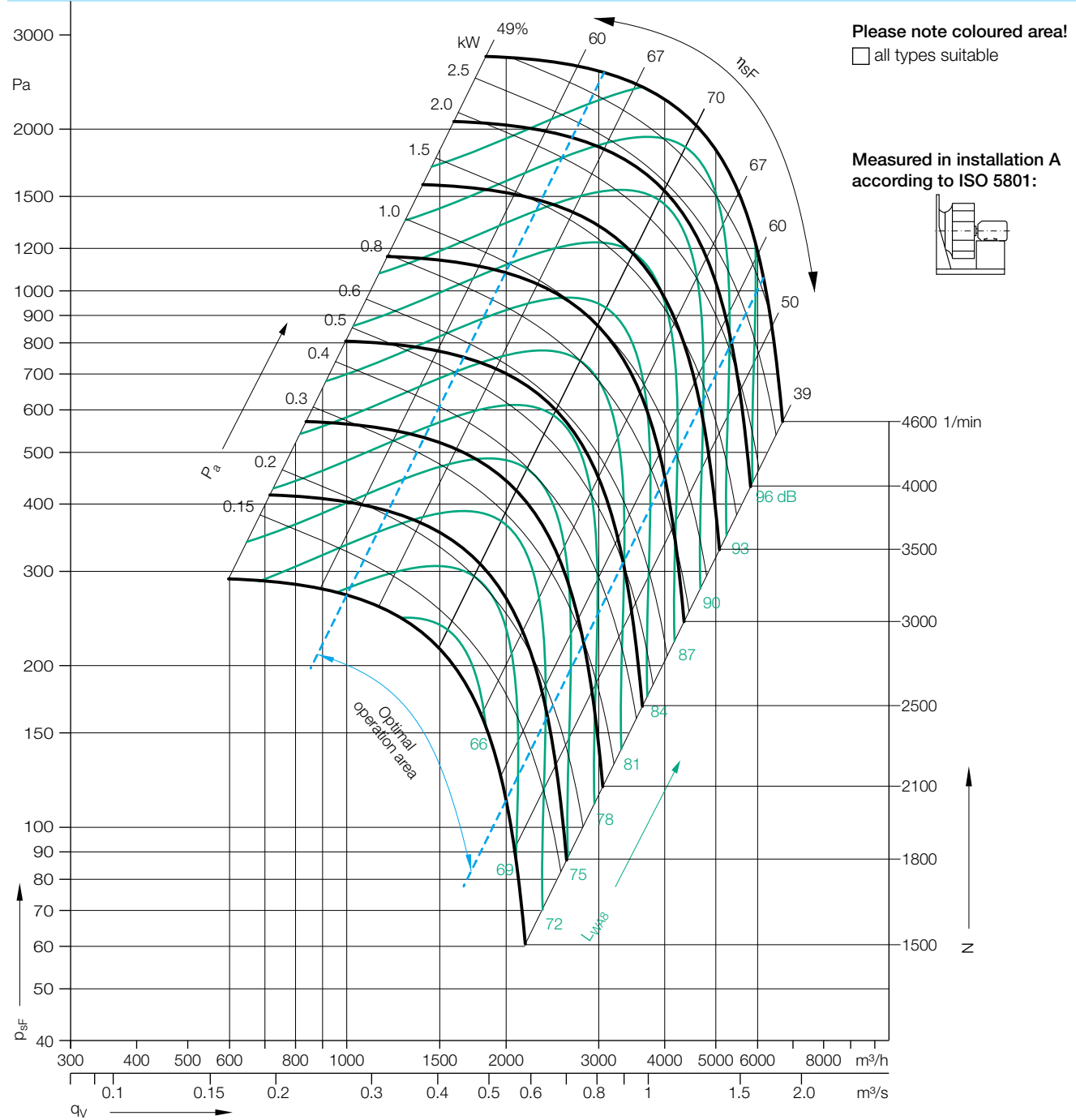

Relative sound power level for discharge side L_{Wrel6} at octave centre frequencies f_m

Relative sound power level for inlet side L_{Wrel5} at octave centre frequencies f_m

Speed
≤3550 1/min
Speed
>3550 1/min

63	125	250	500	1000	2000	4000	8000	Hz
-10	-11	-3	-8	-4	-7	-9	-16	dB
63	125	250	500	1000	2000	4000	8000	Hz
-10	-12	-9	-6	-5	-7	-9	-11	dB

63	125	250	500	1000	2000	4000	8000	Hz
-9	-10	1	-3	-6	-12	-14	-19	dB
63	125	250	500	1000	2000	4000	8000	Hz
-9	-11	-4	0	-6	-11	-12	-14	dB

RLM ..-2831

Technical Data											
	Nominal motor power	Poles	Motor size	Motor voltage	Nominal frequency	Connection	Nominal motor current	Nominal motor speed	Max. fan speed	Max. operating frequency	Weight
RLM 56-	kW	-		V	Hz		A	1/min	1/min	Hz	kg
2831-4D-10	0.55	4	80 M	230/400	50	Δ/Y	2.54/1.46	1395	2380	85	24
2831-2D-11	1.10	2	80 M	230/400	50	Δ/Y	4.25/2.45	2845	3050	53	26
2831-2D-13	1.50	2	90 S	230/400	50	Δ/Y	5.70/3.30	2860	3400	59	30
2831-2D-14	2.20	2	90 L	400/230	50	Δ/Y	8.10/4.70	2880	3830	66	33
2831-2D-16	3.00	2	100 L	400	50	Δ	6.10	2835	4200	74	37
2831-2D-19	4.00	2	112 M	400	50	Δ	8.10	2930	4600	78	42

Technical Data											
	Nominal motor power	Poles	Motor size	Motor voltage	Nominal frequency	Connection	Nominal motor current	Nominal motor speed	Max. fan speed	Max. operating frequency	Weight
RLM 56-Ex II 2G c IIB T4	kW	-		V	Hz		A	1/min	1/min	Hz	kg
2831-4Y-10-2G	0.55	4	80 M	230/400	50	Δ/Y	2.47/1.42	1395	2360	84	39
2831-2Y-11-2G	1.10	2	80 M	230/400	50	Δ/Y	4.30/2.45	2835	3040	53	41
2831-2Y-14-2G	1.50	2	90 La	230/400	50	Δ/Y	5.70/3.30	2850	3360	59	49
2831-2Y-15-2G	2.20	2	90 Lb	230/400	50	Δ/Y	8.00/4.60	2860	3830	67	52
2831-2Y-16-2G	3.00	2	100 L	400	50	Δ	6.20	2885	4200	72	61
2831-2Y-19-2G	4.00	2	112 M	400	50	Δ	7.80	2895	4470	77	74

Dimensions in mm, subject to change.

RLM 56-2831

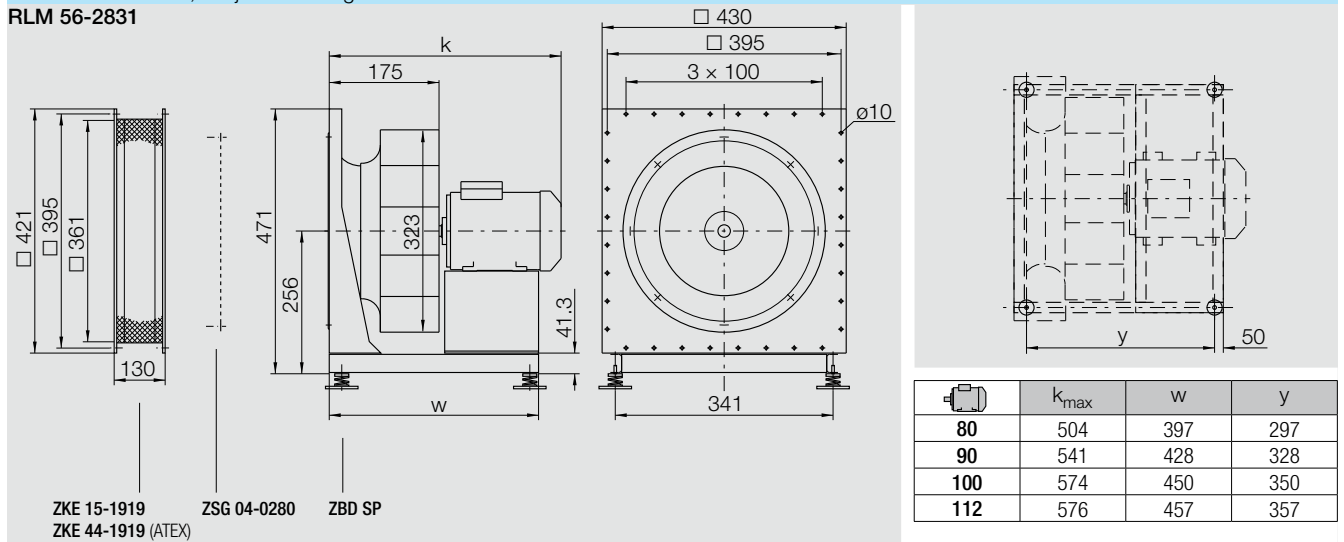

Accessories

	Frequency Inverter Unit MM420 for 3~	Frequency Inverter Unit G110 for 1~	Line Choke for 3~	Line Choke for 1~
RLM 56-				
2831-4D-10	MM420 3AC 400V 0.55KW EMV B	G110 1AC 230V 0.55KW EMV B	6SE6400-3CC00-2AD3	6SE6400-3CC01-0AB3
2831-2D-11	MM420 3AC 400V 1.10KW EMV B	G110 1AC 230V 1.10KW EMV B	6SE6400-3CC00-4AD3	6SE6400-3CC02-6BB3
2831-2D-13	MM420 3AC 400V 1.50KW EMV B	G110 1AC 230V 1.50KW EMV B	6SE6400-3CC00-6AD3	6SE6400-3CC02-6BB3
2831-2D-14	MM420 3AC 400V 2.20KW EMV B	G110 1AC 230V 2.20KW EMV B	6SE6400-3CC01-0BD3	6SE6400-3CC02-6BB3
2831-2D-16	MM420 3AC 400V 3.00KW EMV B	-	6SE6400-3CC01-0BD3	-
2831-2D-19	MM420 3AC 400V 4.00KW EMV B	-	6SE6400-3CC01-4BD3	-
RLM 56-Ex II 2G c IIB T4				
2831-4Y-10-2G	MM420 3AC 400V 0.55KW EMV B	G110 1AC 230V 0.55KW EMV B	6SE6400-3CC00-2AD3	6SE6400-3CC01-0AB3
2831-2Y-11-2G	MM420 3AC 400V 1.10KW EMV B	G110 1AC 230V 1.10KW EMV B	6SE6400-3CC00-4AD3	6SE6400-3CC02-6BB3
2831-2Y-14-2G	MM420 3AC 400V 1.50KW EMV B	G110 1AC 230V 1.50KW EMV B	6SE6400-3CC00-6AD3	6SE6400-3CC02-6BB3
2831-2Y-15-2G	MM420 3AC 400V 2.20KW EMV B	G110 1AC 230V 2.20KW EMV B	6SE6400-3CC01-0BD3	6SE6400-3CC02-6BB3
2831-2Y-16-2G	MM420 3AC 400V 3.00KW EMV B	-	6SE6400-3CC01-0BD3	-
2831-2Y-19-2G	MM420 3AC 400V 4.00KW EMV B	-	6SE6400-3CC01-4BD3	-

RLM ..-3135

Technical Data

Impeller Data

Impeller diameter	D_r	363 mm
Number of blades	z	6
Moment of Inertia	J	0.09 kgm ²

Impeller Data

Impeller weight	m	4.7 kg
Density of media	ρ_1	1.2 kg/m ³
Tolerance class (DIN 24166)		1

Technical Data

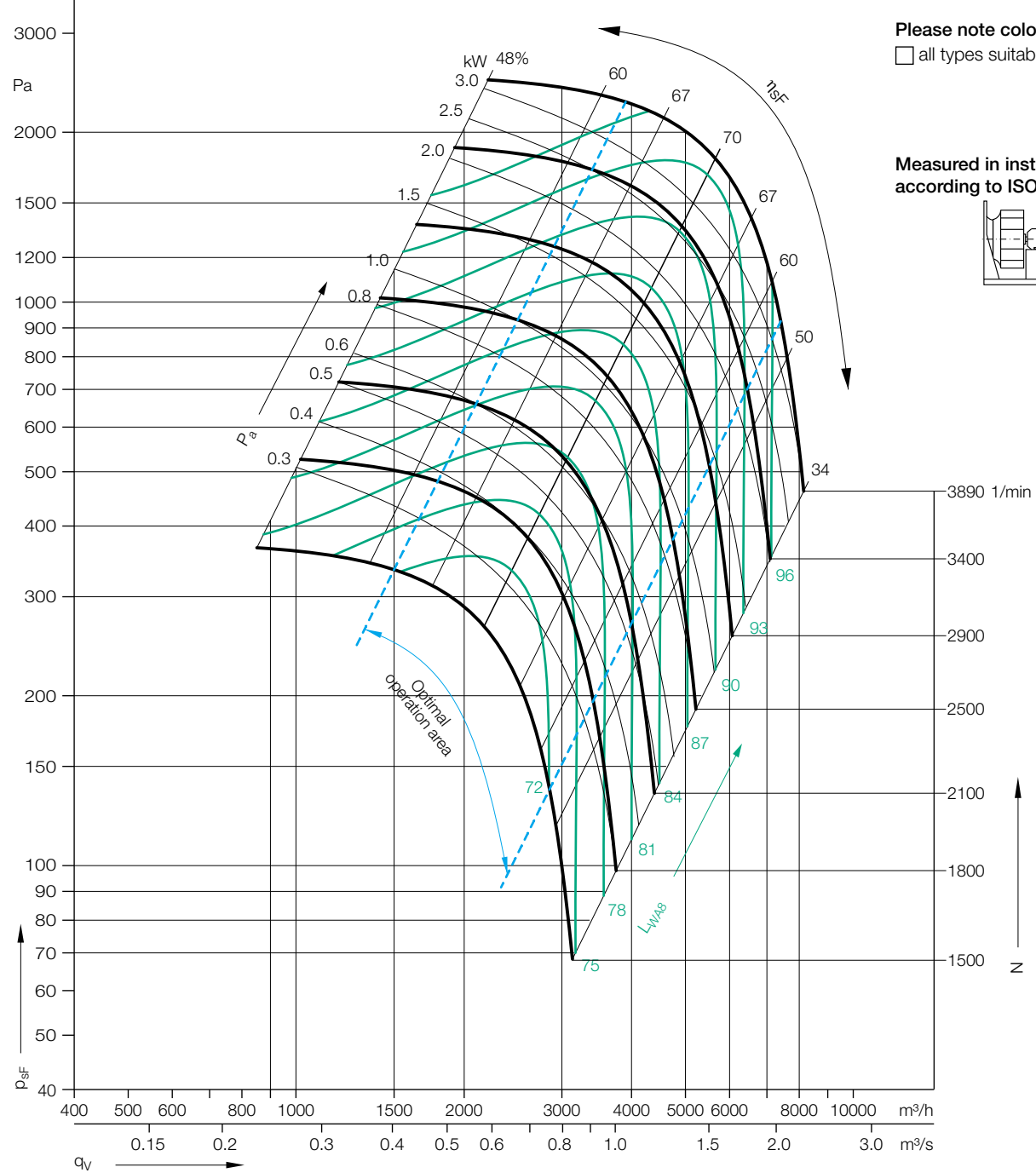

Please note coloured area!

all types suitable

Measured in installation A according to ISO 5801:

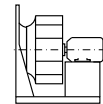

Relative sound power level for discharge side L_{WrelB} at octave centre frequencies f_m

Relative sound power level for inlet side L_{Wrel5} at octave centre frequencies f_m

Speed
≤3550 1/min
Speed
>3550 1/min

63	125	250	500	1000	2000	4000	8000	Hz
-10	-11	-3	-8	-4	-7	-9	-16	dB
63	125	250	500	1000	2000	4000	8000	Hz
-10	-12	-9	-6	-5	-7	-9	-11	dB

63	125	250	500	1000	2000	4000	8000	Hz
-9	-10	1	-3	-6	-12	-14	-19	dB
63	125	250	500	1000	2000	4000	8000	Hz
-9	-11	-4	0	-6	-11	-12	-14	dB

RLM ..-3135

Technical Data											
	Nominal motor power	Poles	Motor size	Motor voltage	Nominal frequency	Connection	Nominal motor current	Nominal motor speed	Max. fan speed	Max. operating frequency	Weight
RLM 56-	kW	-		V	Hz		A	1/min	1/min	Hz	kg
3135-4D-11	0.75	4	80 M	230/400	50	Δ/Y	3.25/1.88	1395	2180	78	28
3135-4D-13	1.10	4	90 S	230/400	50	Δ/Y	4.50/2.60	1415	2500	88	31
3135-2D-14	2.20	2	90 L	230/400	50	Δ/Y	8.10/4.70	2880	3180	55	35
3135-2D-16	3.00	2	100 L	400	50	Δ	6.10	2835	3530	62	39
3135-2D-19	4.00	2	112 M	400	50	Δ	8.10	2930	3890	66	44

Technical Data											
	Nominal motor power	Poles	Motor size	Motor voltage	Nominal frequency	Connection	Nominal motor current	Nominal motor speed	Max. fan speed	Max. operating frequency	Weight
RLM 56-Ex II 2G c IIB T4	kW	-		V	Hz		A	1/min	1/min	Hz	kg
3135-4Y-11-2G	0.75	4	80 M	230/400	50	Δ/Y	3.30/1.88	1395	2180	78	44
3135-4Y-14-2G	1.10	4	90 La	230/400	50	Δ/Y	4.70/2.70	1410	2480	88	50
3135-2Y-15-2G	2.20	2	90 Lb	230/400	50	Δ/Y	8.00/4.60	2860	3150	55	54
3135-2Y-16-2G	3.00	2	100 L	400	50	Δ	6.20	2885	3500	60	63
3135-2Y-19-2G	4.00	2	112 M	400	50	Δ	7.80	2895	3610	62	76

Dimensions in mm, subject to change.

RLM 56-3135

	k_{max}	w	y
80	524	417	317
90	561	448	348
100	594	470	370
112	613	477	377

Accessories

	Frequency Inverter Unit MM420 for 3~	Frequency Inverter Unit G110 for 1~	Line Choke for 3~	Line Choke for 1~
RLM 56-				
3135-4D-11	MM420 3AC 400V 0.75KW EMV B	G110 1AC 230V 0.75KW EMV B	6SE6400-3CC00-4AD3	6SE6400-3CC01-0AB3
3135-4D-13	MM420 3AC 400V 1.10KW EMV B	G110 1AC 230V 1.10KW EMV B	6SE6400-3CC00-4AD3	6SE6400-3CC02-6BB3
3135-2D-14	MM420 3AC 400V 2.20KW EMV B	G110 1AC 230V 2.20KW EMV B	6SE6400-3CC01-0BD3	6SE6400-3CC02-6BB3
3135-2D-16	MM420 3AC 400V 3.00KW EMV B	-	6SE6400-3CC01-0BD3	-
3135-2D-19	MM420 3AC 400V 4.00KW EMV B	-	6SE6400-3CC01-4BD3	-
RLM 56-Ex II 2G c IIB T4				
3135-4Y-11-2G	MM420 3AC 400V 0.75KW EMV B	G110 1AC 230V 0.75KW EMV B	6SE6400-3CC00-4AD3	6SE6400-3CC01-0AB3
3135-4Y-14-2G	MM420 3AC 400V 1.10KW EMV B	G110 1AC 230V 1.10KW EMV B	6SE6400-3CC00-4AD3	6SE6400-3CC02-6BB3
3135-2Y-15-2G	MM420 3AC 400V 2.20KW EMV B	G110 1AC 230V 2.20KW EMV B	6SE6400-3CC01-0BD3	6SE6400-3CC02-6BB3
3135-2Y-16-2G	MM420 3AC 400V 3.00KW EMV B	-	6SE6400-3CC01-0BD3	-
3135-2Y-19-2G	MM420 3AC 400V 4.00KW EMV B	-	6SE6400-3CC01-4BD3	-

RLM ..-3540

Technical Data

Impeller Data

Impeller diameter	D_r	406 mm
Number of blades	z	6
Moment of Inertia	J	0.15 kgm ²

Impeller Data

Impeller weight	m	6.4 kg
Density of media	ρ_1	1.2 kg/m ³
Tolerance class (DIN 24166)		1

Technical Data

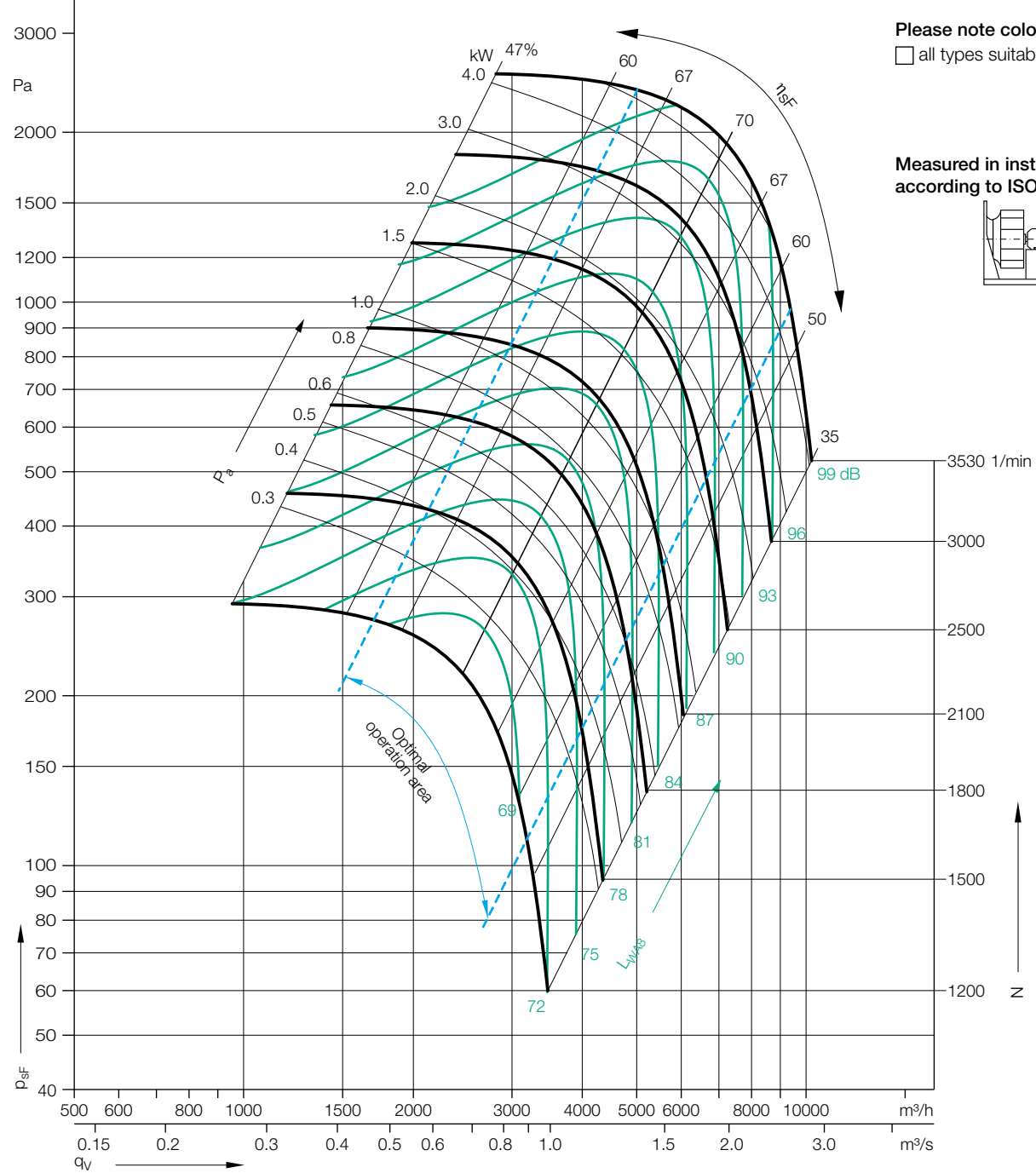

Please note coloured area!

all types suitable

Measured in installation A according to ISO 5801:

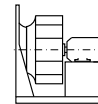

Relative sound power level for discharge side L_{wrel8} at octave centre frequencies f_m

Relative sound power level for inlet side L_{wrel5} at octave centre frequencies f_m

Speed
≤1800 1/min
Speed
>1800 1/min

63	125	250	500	1000	2000	4000	8000	Hz
-7	2	-3	-6	-4	-6	-12	-20	dB
63	125	250	500	1000	2000	4000	8000	Hz
-6	-10	-1	-6	-5	-7	-9	-16	dB

63	125	250	500	1000	2000	4000	8000	Hz
-7	1	-1	-4	-9	-11	-18	-26	dB
63	125	250	500	1000	2000	4000	8000	Hz
-8	-9	2	-3	-9	-12	-14	-20	dB

RLM ..-3540

Technical Data											
	Nominal motor power	Poles	Motor size	Motor voltage	Nominal frequency	Connection	Nominal motor current	Nominal motor speed	Max. fan speed	Max. operating frequency	Weight
RLM 56-	kW	-		V	Hz		A	1/min	1/min	Hz	kg
3540-4D-11	0.75	4	80 M	230/400	50	Δ/Y	3.25/1.88	1395	1810	65	31
3540-4D-13	1.10	4	90 S	230/400	50	Δ/Y	4.50/2.60	1415	2050	72	35
3540-4D-14	1.50	4	90 L	230/400	50	Δ/Y	6.00/3.45	1420	2250	79	38
3540-4D-16	2.20	4	100 L	400	50	Δ	4.75	1475	2480	87	42
3540-2D-16	3.00	2	100 L	400	50	Δ	6.10	2835	2900	51	43
3540-2D-19	4.00	2	112 M	400	50	Δ	8.10	2930	3200	54	48
3540-2D-21	5.50	2	132 S	400	50	Δ	10.60	2905	3530	60	60

Technical Data											
	Nominal motor power	Poles	Motor size	Motor voltage	Nominal frequency	Connection	Nominal motor current	Nominal motor speed	Max. fan speed	Max. operating frequency	Weight
RLM 56-Ex II 2G c IIB T4	kW	-		V	Hz		A	1/min	1/min	Hz	kg
3540-4Y-11-2G	0.75	4	80 M	230/400	50	Δ/Y	3.30/1.88	1395	1810	64	47
3540-4Y-14-2G	1.10	4	90 La	230/400	50	Δ/Y	4.70/2.70	1410	2050	72	54
3540-4Y-15-2G	1.50	4	90 Lb	230/400	50	Δ/Y	6.10/3.50	1420	2250	79	57
3540-4Y-16-2G	2.20	4	100 L	400	50	Δ	5.10	1420	2480	87	68
3540-2Y-16-2G	3.00	2	100 L	400	50	Δ	6.20	2885	2855	49	67
3540-2Y-19-2G	4.00	2	112 M	400	50	Δ	7.80	2895	3140	54	80
3540-2Y-21-2G	5.50	2	132 S	400	50	Δ	10.50	2925	3230	55	100

Dimensions in mm, subject to change.

RLM 56-3540

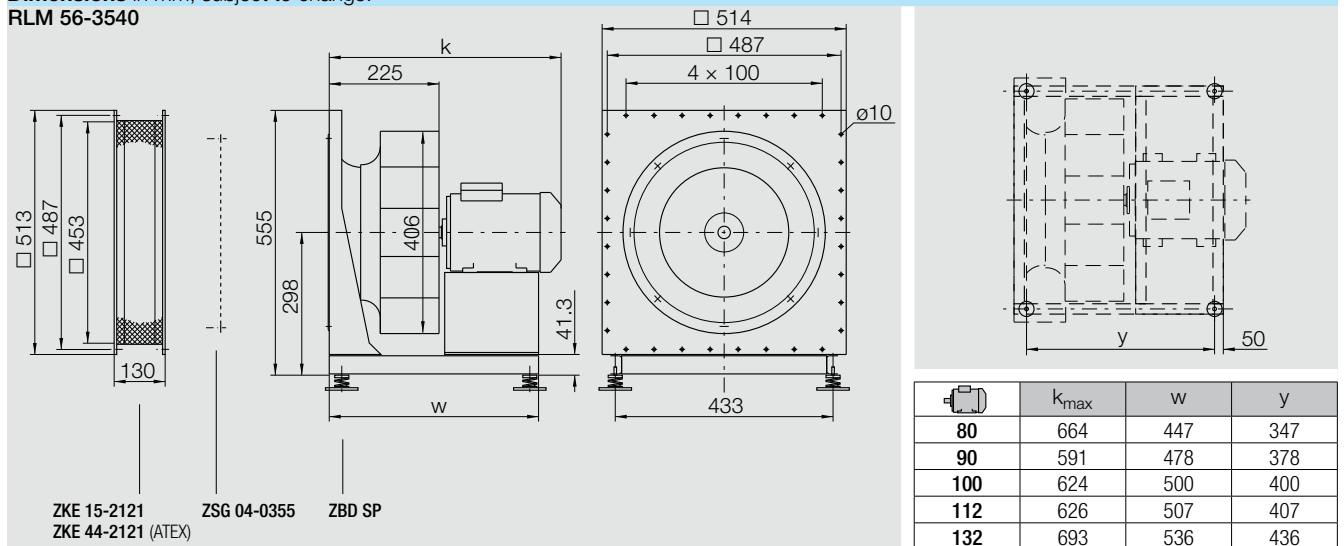

Accessories

	Frequency Inverter Unit MM420 for 3~	Frequency Inverter Unit G110 for 1~	Line Choke for 3~	Line Choke for 1~
RLM 56-				
3540-4D-11	MM420 3AC 400V 0.75KW EMV B	G110 1AC 230V 0.75KW EMV B	6SE6400-3CC00-4AD3	6SE6400-3CC01-0AB3
3540-4D-13	MM420 3AC 400V 1.10KW EMV B	G110 1AC 230V 1.10KW EMV B	6SE6400-3CC00-4AD3	6SE6400-3CC02-6BB3
3540-4D-14	MM420 3AC 400V 1.50KW EMV B	G110 1AC 230V 1.50KW EMV B	6SE6400-3CC00-6AD3	6SE6400-3CC02-6BB3
3540-4D-16	MM420 3AC 400V 2.20KW EMV B	-	6SE6400-3CC01-0BD3	-
3540-2D-16	MM420 3AC 400V 3.00KW EMV B	-	6SE6400-3CC01-0BD3	-
3540-2D-19	MM420 3AC 400V 4.00KW EMV B	-	6SE6400-3CC01-4BD3	-
3540-2D-21	MM420 3AC 400V 5.50KW EMV B	-	6SE6400-3CC02-2CD3	-
RLM 56-Ex II 2G c IIB T4				
3540-4Y-11-2G	MM420 3AC 400V 0.75KW EMV B	G110 1AC 230V 0.75KW EMV B	6SE6400-3CC00-4AD3	6SE6400-3CC01-0AB3
3540-4Y-14-2G	MM420 3AC 400V 1.10KW EMV B	G110 1AC 230V 1.10KW EMV B	6SE6400-3CC00-4AD3	6SE6400-3CC02-6BB3
3540-4Y-15-2G	MM420 3AC 400V 1.50KW EMV B	G110 1AC 230V 1.50KW EMV B	6SE6400-3CC00-6AD3	6SE6400-3CC02-6BB3
3540-4Y-16-2G	MM420 3AC 400V 2.20KW EMV B	-	6SE6400-3CC01-0BD3	-
3540-2Y-16-2G	MM420 3AC 400V 3.00KW EMV B	-	6SE6400-3CC01-0BD3	-
3540-2Y-19-2G	MM420 3AC 400V 4.00KW EMV B	-	6SE6400-3CC01-4BD3	-
3540-2Y-21-2G	MM420 3AC 400V 5.50KW EMV B	-	6SE6400-3CC02-2CD3	-

RLM ..-4045

Technical Data

Impeller Data

Impeller diameter	D_r	455	mm
Number of blades	z	6	
Moment of Inertia	J	0.27	kgm ²

Impeller Data

Impeller weight	m	9	kg
Density of media	ρ_1	1.2	kg/m ³
Tolerance class (DIN 24166)		1	

Technical Data

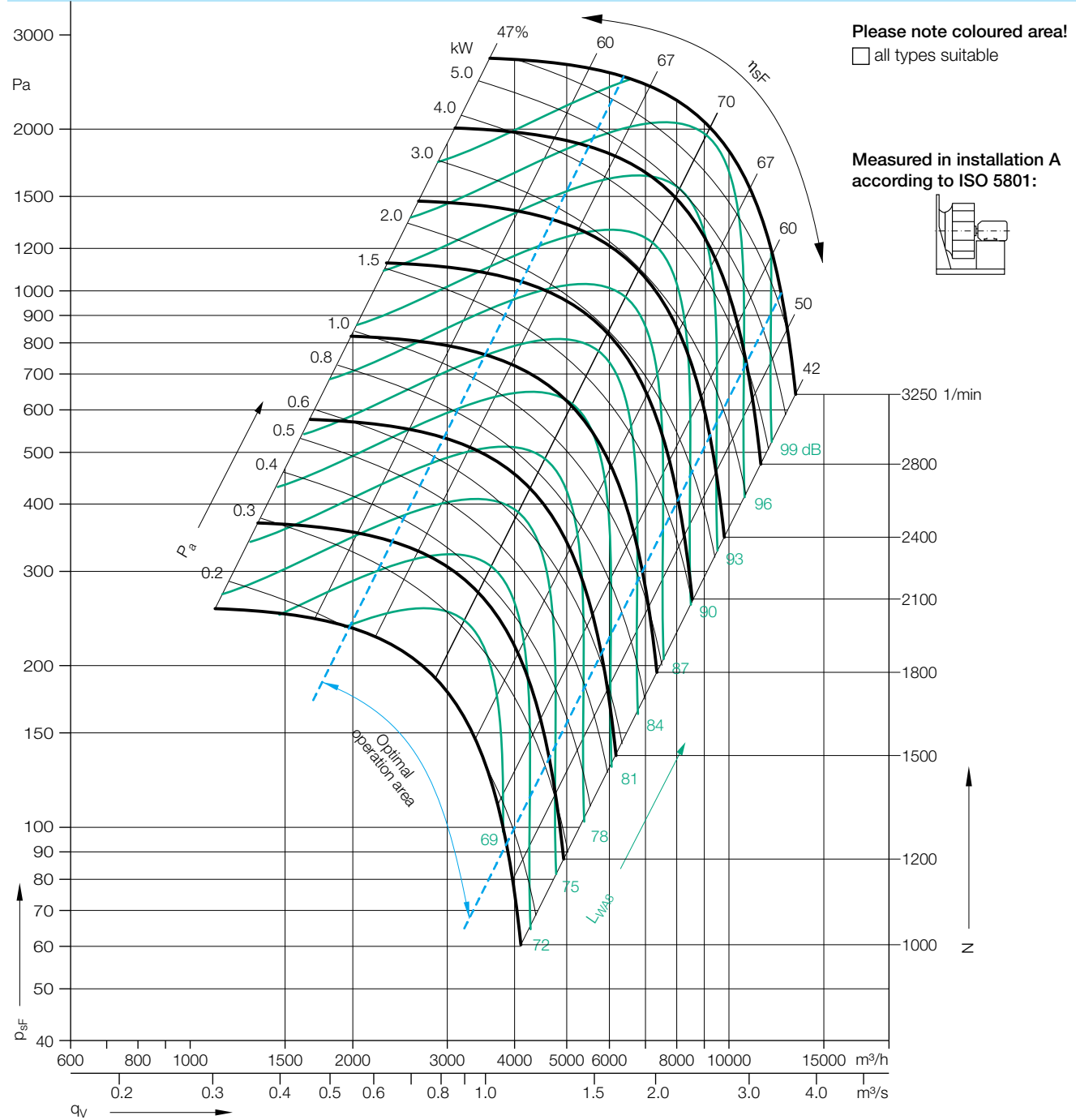

Relative sound power level for discharge side L_{Wrel6} at octave centre frequencies f_m

Relative sound power level for inlet side L_{Wrel5} at octave centre frequencies f_m

Speed
≤1800 1/min
Speed
>1800 1/min

63	125	250	500	1000	2000	4000	8000	Hz
-7	2	-3	-6	-4	-6	-12	-20	dB
63	125	250	500	1000	2000	4000	8000	Hz
-6	-10	-1	-6	-5	-7	-9	-16	dB

63	125	250	500	1000	2000	4000	8000	Hz
-7	1	-1	-4	-9	-11	-18	-26	dB
63	125	250	500	1000	2000	4000	8000	Hz
-8	-9	2	-3	-9	-12	-14	-20	dB

RLM ..-4045

Technical Data

	Nominal motor power kW	Poles -	Motor size	Motor voltage V	Nominal frequency Hz	Connection	Nominal motor current A	Nominal motor speed 1/min	Max. fan speed 1/min	Max. operating frequency Hz	Weight kg
RLM 56-											
4045-4D-13	1.10	4	90 S	230/400	50	Δ/Y	4.50/2.60	1415	1700	60	40
4045-4D-14	1.50	4	90 L	230/400	50	Δ/Y	6.00/3.45	1420	1900	67	44
4045-4D-16	2.20	4	100 L	400	50	Δ	4.75	1425	2130	75	47
4045-4D-17	3.00	4	100 L	400	50	Δ	6.30	1425	2350	82	52
4045-2D-21	5.50	2	132 S	400	50	Δ	10.60	2905	2950	50	66
4045-2D-22	7.50	2	132 S	400	50	Δ	14.40	2925	3250	55	70

Technical Data

	Nominal motor power kW	Poles -	Motor size	Motor voltage V	Nominal frequency Hz	Connection	Nominal motor current A	Nominal motor speed 1/min	Max. fan speed 1/min	Max. operating frequency Hz	Weight kg
RLM 56-Ex II 2G c IIB T4											
4045-4Y-14-2G	1.10	4	90 La	230/400	50	Δ/Y	4.70/2.70	1410	1700	60	59
4045-4Y-15-2G	1.50	4	90 Lb	230/400	50	Δ/Y	6.10/3.50	1420	1890	66	63
4045-4Y-16-2G	2.20	4	100 L	400	50	Δ	5.10	1420	2130	75	73
4045-4Y-17-2G	3.00	4	100 L	400	50	Δ	6.60	1415	2350	83	87
4045-2Y-21-2G	5.50	2	132 S	400	50	Δ	10.50	2925	2905	49	106
4045-2Y-22-2G	7.50	2	132 S	400	50	Δ	14.00	2930	3210	54	105

Dimensions in mm, subject to change.

RLM 56-4045

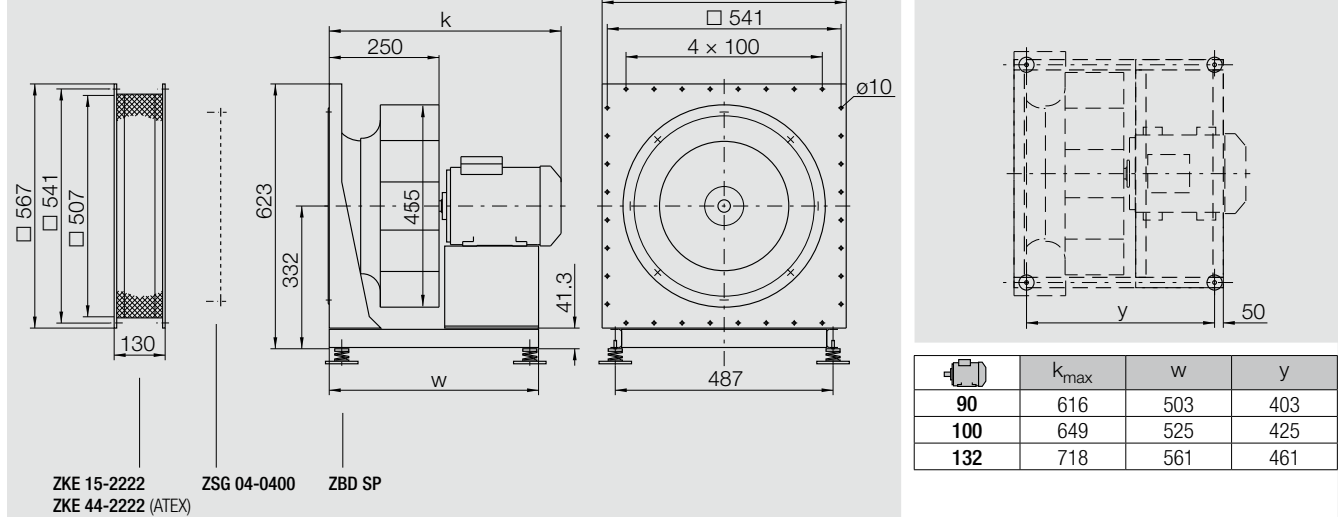

Accessories

	Frequency Inverter Unit MM420 for 3~	Frequency Inverter Unit G110 for 1~	Line Choke for 3~	Line Choke for 1~
RLM 56-				
4045-4D-13	MM420 3AC 400V 1.10KW EMV B	G110 1AC 230V 1.10KW EMV B	6SE6400-3CC00-4AD3	6SE6400-3CC02-6BB3
4045-4D-14	MM420 3AC 400V 1.50KW EMV B	G110 1AC 230V 1.50KW EMV B	6SE6400-3CC00-6AD3	6SE6400-3CC02-6BB3
4045-4D-16	MM420 3AC 400V 2.20KW EMV B	-	6SE6400-3CC01-0BD3	-
4045-4D-17	MM420 3AC 400V 3.00KW EMV B	-	6SE6400-3CC01-0BD3	-
4045-2D-21	MM420 3AC 400V 5.50KW EMV B	-	6SE6400-3CC02-2CD3	-
4045-2D-22	MM420 3AC 400V 7.50KW EMV B	-	6SE6400-3CC02-2CD3	-
RLM 56-Ex II 2G c IIB T4				
4045-4Y-14-2G	MM420 3AC 400V 1.10KW EMV B	G110 1AC 230V 1.10KW EMV B	6SE6400-3CC00-4AD3	6SE6400-3CC02-6BB3
4045-4Y-15-2G	MM420 3AC 400V 1.50KW EMV B	G110 1AC 230V 1.50KW EMV B	6SE6400-3CC00-6AD3	6SE6400-3CC02-6BB3
4045-4Y-16-2G	MM420 3AC 400V 2.20KW EMV B	-	6SE6400-3CC01-0BD3	-
4045-4Y-17-2G	MM420 3AC 400V 3.00KW EMV B	-	6SE6400-3CC01-0BD3	-
4045-2Y-21-2G	MM420 3AC 400V 5.50KW EMV B	-	6SE6400-3CC02-2CD3	-
4045-2Y-22-2G	MM420 3AC 400V 7.50KW EMV B	-	6SE6400-3CC02-2CD3	-

RLM ..-4550

Technical Data

Impeller Data

Impeller diameter	D_r	510 mm
Number of blades	z	6
Moment of Inertia	J	0.6 kgm ²

Impeller Data

Impeller weight	m	15 kg
Density of media	ρ_1	1.2 kg/m ³
Tolerance class (DIN 24166)		1

Technical Data

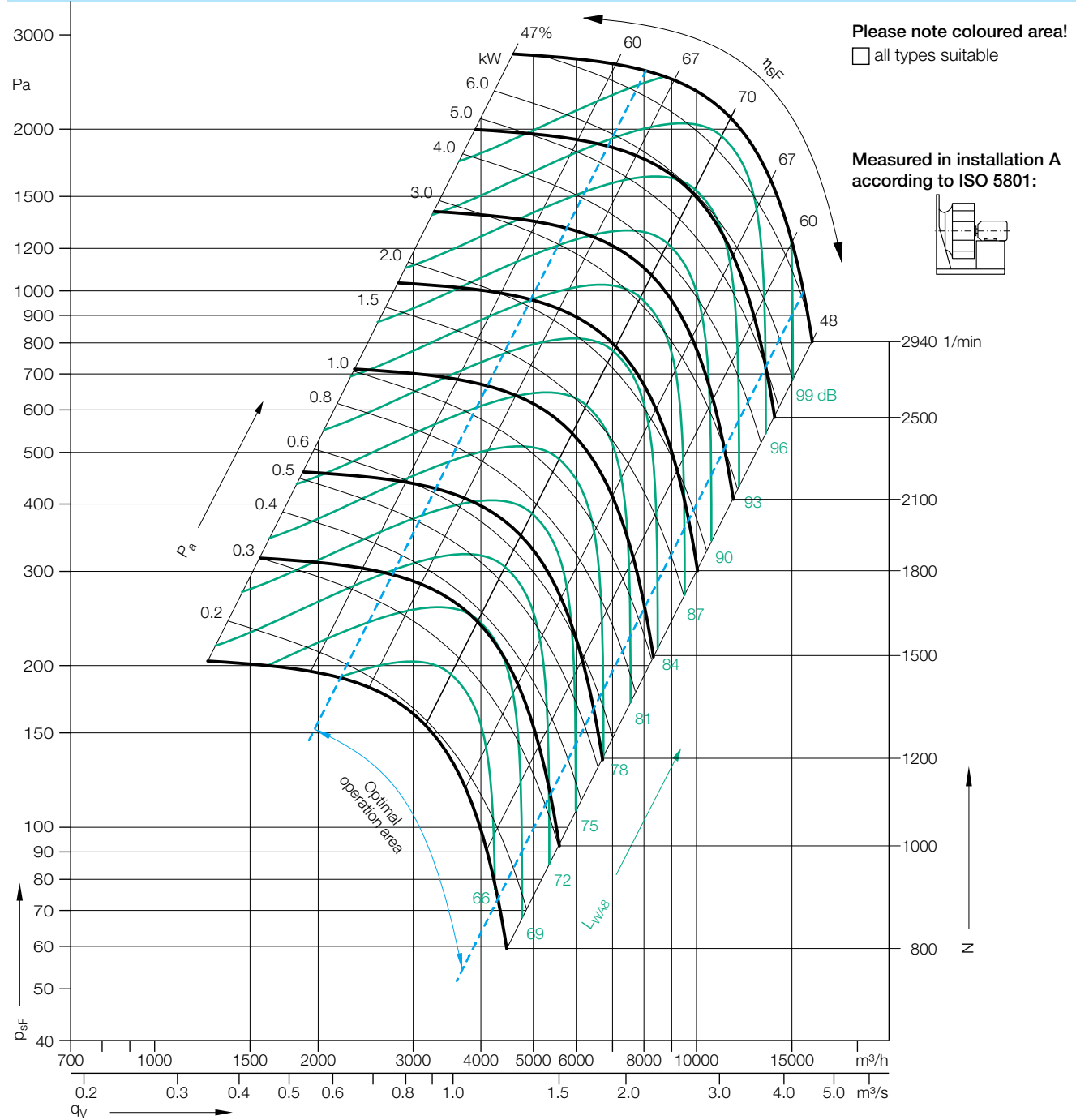

Relative sound power level for discharge side L_{Wrel8} at octave centre frequencies f_m

Relative sound power level for inlet side L_{Wrel5} at octave centre frequencies f_m

Speed
≤1800 1/min
Speed
>1800 1/min

63	125	250	500	1000	2000	4000	8000	Hz
-7	2	-3	-6	-4	-6	-12	-20	dB
63	125	250	500	1000	2000	4000	8000	Hz
-6	-10	-1	-6	-5	-7	-9	-16	dB

63	125	250	500	1000	2000	4000	8000	Hz
-4	5	0	-4	-9	-11	-18	-26	dB
63	125	250	500	1000	2000	4000	8000	Hz
-5	-5	3	-3	-9	-12	-14	-20	dB

RLM ..-4550

Technical Data											
	Nominal motor power	Poles	Motor size	Motor voltage	Nominal frequency	Connection	Nominal motor current	Nominal motor speed	Max. fan speed	Max. operating frequency	Weight
RLM 56-	kW	-		V	Hz		A	1/min	1/min	Hz	kg
4550-4D-14	1.50	4	90 L	230/400	50	Δ/Y	6.00/3.45	1420	1580	55	54
4550-4D-16	2.20	4	100 L	400	50	Δ	4.75	1425	1780	62	58
4550-4D-17	3.00	4	100 L	400	50	Δ	6.30	1425	1960	69	62
4550-4D-19	4.00	4	112 M	400	50	Δ	8.20	1435	2150	75	66
4550-4D-21	5.50	4	132 S	400	50	Δ	11.40	1450	2380	82	80
4550-4D-23	7.50	4	132 M	400	50	Δ	15.40	1450	2600	89	84
4550-2D-26	11.00	2	160 M	400	50	Δ	21.50	2920	2940	50	107

Technical Data											
	Nominal motor power	Poles	Motor size	Motor voltage	Nominal frequency	Connection	Nominal motor current	Nominal motor speed	Max. fan speed	Max. operating frequency	Weight
RLM 56-Ex II 2G c IIB T4	kW	-		V	Hz		A	1/min	1/min	Hz	kg
4550-4Y-15-2G	1.50	4	90 Lb	230/400	50	Δ/Y	6.10	1420	1560	55	73
4550-4Y-16-2G	2.20	4	100 L	400	50	Δ	5.10	1420	1780	62	84
4550-4Y-17-2G	3.00	4	100 L	400	50	Δ	6.60	1415	1960	69	87
4550-4Y-19-2G	4.00	4	112 M	400	50	Δ	8.50	1435	2150	75	97
4550-4Y-21-2G	5.50	4	132 S	400	50	Δ	11.10	1450	2380	82	118
4550-4Y-23-2G	7.50	4	132 M	400	50	Δ	15.00	1450	2600	89	125

Dimensions in mm, subject to change.

RLM 56-4550

	k_{max}	w	y
90	643	530	430
100	676	552	452
112	678	559	459
132	745	598	498
160	803	697	597

Accessories

	Frequency Inverter Unit MM420 for 3~	Frequency Inverter Unit G110 for 1~	Line Choke for 3~	Line Choke for 1~
RLM 56-				
4550-4D-14	MM420 3AC 400V 1.50KW EMV B	G110 1AC 230V 1.50KW EMV B	6SE6400-3CC00-6AD3	6SE6400-3CC02-6BB3
4550-4D-16	MM420 3AC 400V 2.20KW EMV B	-	6SE6400-3CC01-0BD3	-
4550-4D-17	MM420 3AC 400V 3.00KW EMV B	-	6SE6400-3CC01-0BD3	-
4550-4D-19	MM420 3AC 400V 4.00KW EMV B	-	6SE6400-3CC01-4BD3	-
4550-4D-21	MM420 3AC 400V 5.50KW EMV B	-	6SE6400-3CC02-2CD3	-
4550-4D-23	MM420 3AC 400V 7.50KW EMV B	-	6SE6400-3CC02-2CD3	-
4550-2D-26	MM420 3AC 400V 11.0KW EMV B	-	6SE6400-3CC03-5CD3	-
RLM 56-Ex II 2G c IIB T4				
4550-4Y-15-2G	MM420 3AC 400V 1.50KW EMV B	G110 1AC 230V 1.50KW EMV B	6SE6400-3CC00-6AD3	6SE6400-3CC02-6BB3
4550-4Y-16-2G	MM420 3AC 400V 2.20KW EMV B	-	6SE6400-3CC01-0BD3	-
4550-4Y-17-2G	MM420 3AC 400V 3.00KW EMV B	-	6SE6400-3CC01-0BD3	-
4550-4Y-19-2G	MM420 3AC 400V 4.00KW EMV B	-	6SE6400-3CC01-4BD3	-
4550-4Y-21-2G	MM420 3AC 400V 5.50KW EMV B	-	6SE6400-3CC02-2CD3	-
4550-4Y-23-2G	MM420 3AC 400V 7.50KW EMV B	-	6SE6400-3CC02-2CD3	-

RLM ..-5056

Technical Data

Impeller Data

Impeller diameter	D_r	570 mm
Number of blades	z	6
Moment of Inertia	J	0.9 kgm ²

Impeller Data

Impeller weight	m	23.5 kg
Density of media	ρ_1	1.2 kg/m ³
Tolerance class (DIN 24166)		1

Technical Data

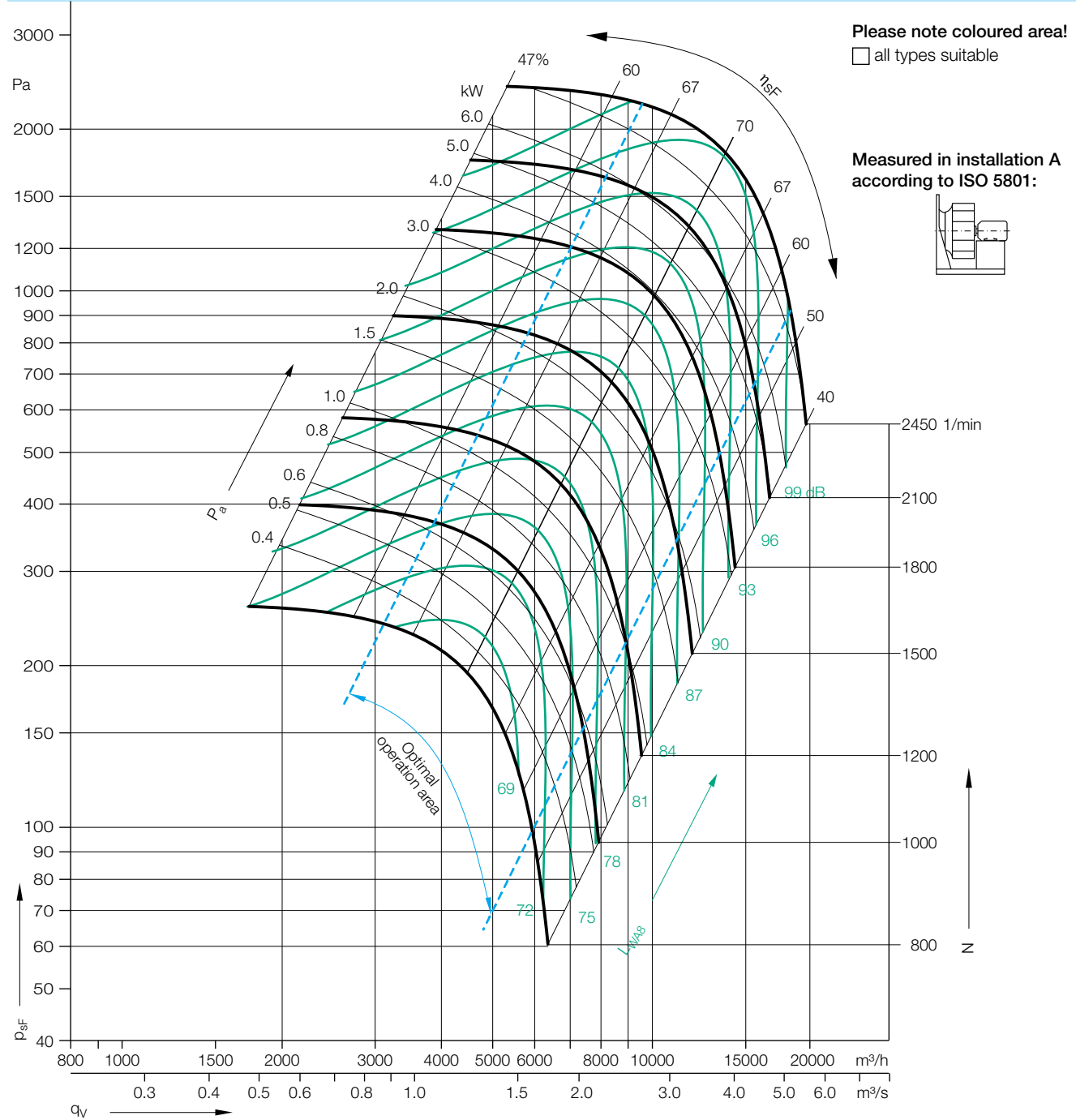

Relative sound power level for discharge side L_{Wrel6} at octave centre frequencies f_m

Relative sound power level for inlet side L_{Wrel5} at octave centre frequencies f_m

Speed
≤1800 1/min
Speed
>1800 1/min

63	125	250	500	1000	2000	4000	8000	Hz
-3	2	-4	-4	-5	-6	-14	-17	dB
63	125	250	500	1000	2000	4000	8000	Hz
-7	-8	-3	-2	-6	-8	-11	-17	dB

63	125	250	500	1000	2000	4000	8000	Hz
-2	4	-1	-4	-7	-9	-15	-17	dB
63	125	250	500	1000	2000	4000	8000	Hz
-6	-4	1	-1	-9	-12	-14	-17	dB

RLM ..-5056

Technical Data											
	Nominal motor power	Poles	Motor size	Motor voltage	Nominal frequency	Connection	Nominal motor current	Nominal motor speed	Max. fan speed	Max. operating frequency	Weight
RLM 56-	kW	-		V	Hz		A	1/min	1/min	Hz	kg
5056-6D-16	1.50	6	100 L	230/400	50	Δ/Y	6.80/3.90	940	1280	68	73
5056-4D-16	2.20	4	100 L	400	50	Δ	4.75	1425	1460	51	70
5056-4D-17	3.00	4	100 L	400	50	Δ	6.30	1425	1630	57	74
5056-4D-19	4.00	4	112 M	400	50	Δ	8.20	1435	1780	62	78
5056-4D-21	5.50	4	132 S	400	50	Δ	11.40	1450	1980	68	94
5056-4D-23	7.50	4	132 M	400	50	Δ	15.40	1450	2200	76	98
5056-4D-26	11.00	4	160 M	400	50	Δ	22.00	1460	2450	84	116

Technical Data											
	Nominal motor power	Poles	Motor size	Motor voltage	Nominal frequency	Connection	Nominal motor current	Nominal motor speed	Max. fan speed	Max. operating frequency	Weight
RLM 56-Ex II 2G c IIB T4	kW	-		V	Hz		A	1/min	1/min	Hz	kg
5056-6Y-16-2G	1.50	6	100 L	230/400	50	Δ/Y	7.00/4.00	930	1280	68	93
5056-4Y-16-2G	2.20	4	100 L	400	50	Δ	5.10	1420	1460	51	98
5056-4Y-17-2G	3.00	4	100 L	400	50	Δ	6.60	1415	1620	57	96
5056-4Y-19-2G	4.00	4	112 M	400	50	Δ	8.50	1435	1780	62	103
5056-4Y-21-2G	5.50	4	132 S	400	50	Δ	11.10	1450	1980	68	117
5056-4Y-23-2G	7.50	4	132 M	400	50	Δ	15.00	1450	2200	75	139
5056-4Y-26-2G	11.00	4	160 M	400	50	Δ	21.50	1455	2380	81	182

Dimensions in mm, subject to change.

RLM 56-5056

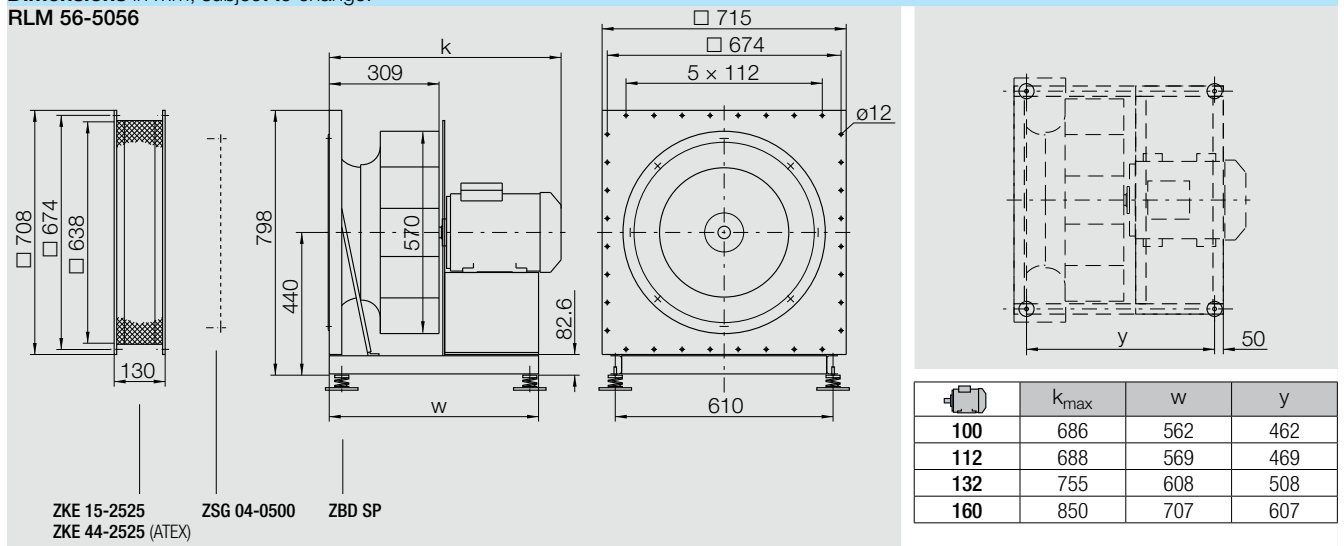

Accessories

	Frequency Inverter Unit MM420 for 3~	Frequency Inverter Unit G110 for 1~	Line Choke for 3~	Line Choke for 1~
RLM 56-				
5056-6D-16	MM420 3AC 400V 1.50KW EMV B	G110 1AC 230V 1.50KW EMV B	6SE6400-3CC00-6AD3	6SE6400-3CC02-6BB3
5056-4D-16	MM420 3AC 400V 2.20KW EMV B	-	6SE6400-3CC01-0BD3	-
5056-4D-17	MM420 3AC 400V 3.00KW EMV B	-	6SE6400-3CC01-0BD3	-
5056-4D-19	MM420 3AC 400V 4.00KW EMV B	-	6SE6400-3CC01-4BD3	-
5056-4D-21	MM420 3AC 400V 5.50KW EMV B	-	6SE6400-3CC02-2CD3	-
5056-4D-23	MM420 3AC 400V 7.50KW EMV B	-	6SE6400-3CC02-2CD3	-
5056-4D-26	MM420 3AC 400V 11.0KW EMV B	-	6SE6400-3CC03-5CD3	-
RLM 56-Ex II 2G c IIB T4				
5056-6Y-16-2G	MM420 3AC 400V 1.50KW EMV B	G110 1AC 230V 1.50KW EMV B	6SE6400-3CC00-6AD3	6SE6400-3CC02-6BB3
5056-4Y-16-2G	MM420 3AC 400V 2.20KW EMV B	-	6SE6400-3CC01-0BD3	-
5056-4Y-17-2G	MM420 3AC 400V 3.00KW EMV B	-	6SE6400-3CC01-0BD3	-
5056-4Y-19-2G	MM420 3AC 400V 4.00KW EMV B	-	6SE6400-3CC01-4BD3	-
5056-4Y-21-2G	MM420 3AC 400V 5.50KW EMV B	-	6SE6400-3CC02-2CD3	-
5056-4Y-23-2G	MM420 3AC 400V 7.50KW EMV B	-	6SE6400-3CC02-2CD3	-
5056-4Y-26-2G	MM420 3AC 400V 11.0KW EMV B	-	6SE6400-3CC03-5CD3	-

RLM ..-5663

Technical Data

Impeller Data

Impeller diameter	D_r	640 mm
Number of blades	z	6
Moment of Inertia	J	1.4 kgm ²

Impeller Data

Impeller weight	m	28 kg
Density of media	ρ_1	1.2 kg/m ³
Tolerance class (DIN 24166)		1

Technical Data

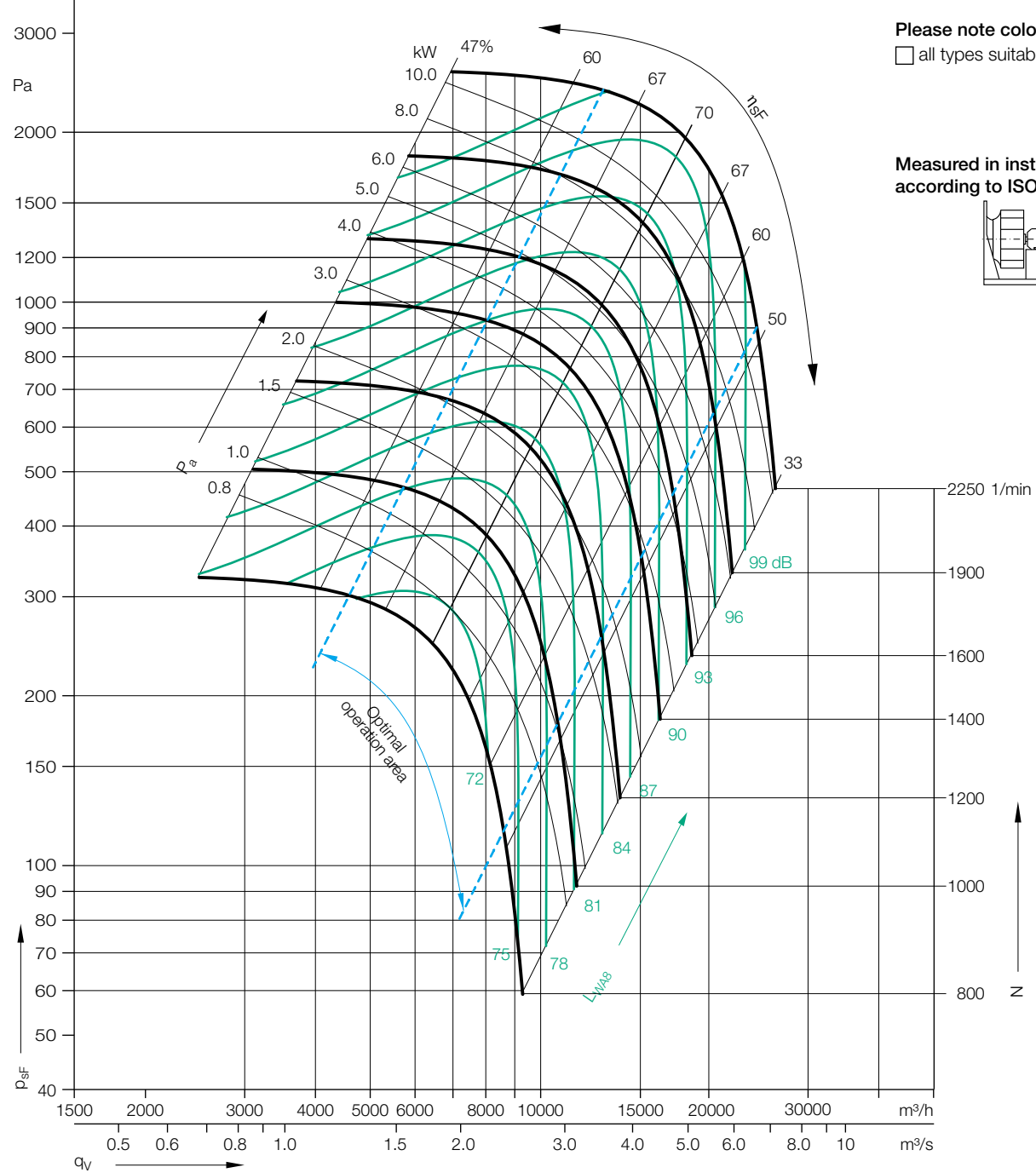

Relative sound power level for discharge side L_{Wrel6} at octave centre frequencies f_m

Relative sound power level for inlet side L_{Wrel5} at octave centre frequencies f_m

Speed
≤1800 1/min
Speed
>1800 1/min

63	125	250	500	1000	2000	4000	8000	Hz
-3	2	-4	-4	-5	-6	-14	-17	dB
63	125	250	500	1000	2000	4000	8000	Hz
-7	-8	-3	-2	-6	-8	-11	-17	dB

63	125	250	500	1000	2000	4000	8000	Hz
-2	4	-1	-4	-7	-9	-15	-17	dB
63	125	250	500	1000	2000	4000	8000	Hz
-6	-4	1	-1	-9	-12	-14	-17	dB

RLM ..-5663

Technical Data											
	Nominal motor power	Poles	Motor size	Motor voltage	Nominal frequency	Connection	Nominal motor current	Nominal motor speed	Max. fan speed	Max. operating frequency	Weight
RLM 56-	kW	-		V	Hz		A	1/min	1/min	Hz	kg
5663-6D-19	2.20	6	112 M	400	50	Δ	5.30	930	1190	64	88
5663-6D-21	3.00	6	132 S	400	50	Δ	7.30	955	1310	68	100
5663-4D-19	4.00	4	112 M	400	50	Δ	8.20	1435	1460	51	89
5663-4D-21	5.50	4	132 S	400	50	Δ	11.40	1450	1630	56	103
5663-4D-23	7.50	4	132 M	400	50	Δ	15.40	1450	1800	62	107
5663-4D-26	11.00	4	160 M	400	50	Δ	22.00	1460	2030	69	130
5663-4D-28	15.00	4	160 L	400	50	Δ	30.00	1460	2250	77	154

Technical Data											
	Nominal motor power	Poles	Motor size	Motor voltage	Nominal frequency	Connection	Nominal motor current	Nominal motor speed	Max. fan speed	Max. operating frequency	Weight
RLM 56-Ex II 2G c IIB T4	kW	-		V	Hz		A	1/min	1/min	Hz	kg
5663-6Y-19-2G	2.20	6	112 M	400	50	Δ	5.50	945	1190	63	115
5663-6Y-21-2G	3.00	6	132 S	400	50	Δ	7.40	945	1310	69	144
5663-4Y-19-2G	4.00	4	112 M	400	50	Δ	8.50	1435		50	120
5663-4Y-21-2G	5.50	4	132 S	400	50	Δ	11.10	1450		55	141
5663-4Y-23-2G	7.50	4	132 M	400	50	Δ	15.00	1450		61	148
5663-4Y-26-2G	11.00	4	160 M	400	50	Δ	21.50	1455		69	196

Dimensions in mm, subject to change.

RLM 56-5663

	k_{max}	w	y
112	729	615	515
132	796	649	549
160	891	748	648

Accessories				
	Frequency Inverter Unit MM420 for 3~	Line Choke for 3~	Frequency Inverter 6SE6430-	Control Panel for Frequency Inverter 6SE6420- and 6SE6430-
RLM 56-				
5663-6D-19	MM420 3AC 400V 2.20KW EMV B	6SE6400-3CC01-0BD3	-	-
5663-6D-21	MM420 3AC 400V 3.00KW EMV B	6SE6400-3CC01-0BD3	-	-
5663-4D-19	MM420 3AC 400V 4.00KW EMV B	6SE6400-3CC01-4BD3	-	-
5663-4D-21	MM420 3AC 400V 5.50KW EMV B	6SE6400-3CC02-2CD3	-	-
5663-4D-23	MM420 3AC 400V 7.50KW EMV B	6SE6400-3CC02-2CD3	-	-
5663-4D-26	MM420 3AC 400V 11.0KW EMV B	6SE6400-3CC03-5CD3	-	-
5663-4D-28	-	6SE6400-3CC03-5CD3	6SE6430-2AD31-5CA0	6SE6400-0BP00-0AA0
RLM 56-Ex II 2G c IIB T4				
5663-6Y-19-2G	MM420 3AC 400V 2.20KW EMV B	6SE6400-3CC01-0BD3	-	-
5663-6Y-21-2G	MM420 3AC 400V 3.00KW EMV B	6SE6400-3CC01-0BD3	-	-
5663-4Y-19-2G	MM420 3AC 400V 4.00KW EMV B	6SE6400-3CC01-4BD3	-	-
5663-4Y-21-2G	MM420 3AC 400V 5.50KW EMV B	6SE6400-3CC02-2CD3	-	-
5663-4Y-23-2G	MM420 3AC 400V 7.50KW EMV B	6SE6400-3CC02-2CD3	-	-
5663-4Y-26-2G	MM420 3AC 400V 11.0KW EMV B	6SE6400-3CC03-5CD3	-	-

RLM ..-6371

Technical Data

Impeller Data

Impeller diameter	D_r	718 mm
Number of blades	z	6
Moment of Inertia	J	3 kgm ²

Impeller Data

Impeller weight	m	41 kg
Density of media	ρ_1	1.2 kg/m ³
Tolerance class (DIN 24166)		1

Technical Data

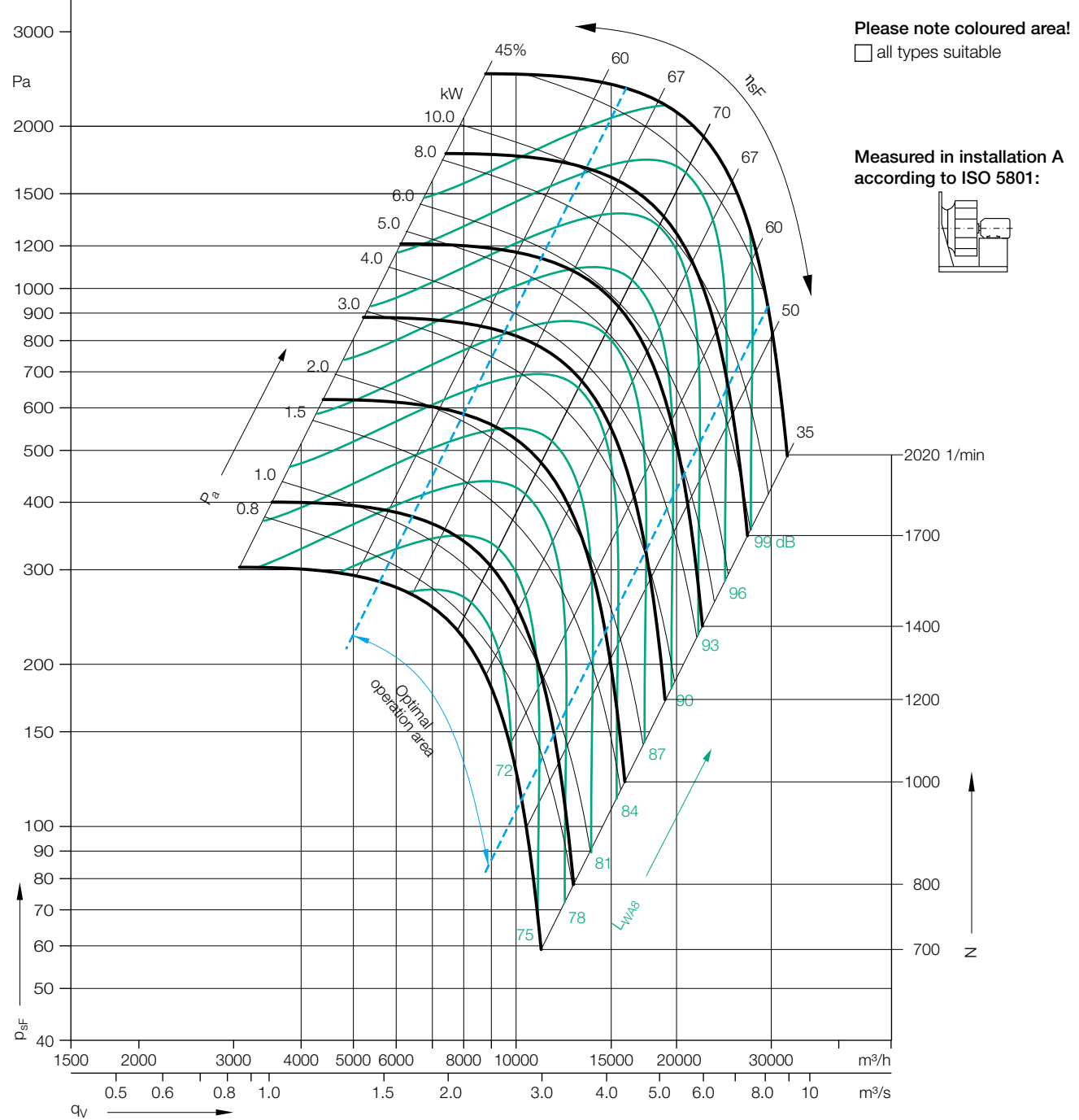

Relative sound power level for discharge side L_{Wrel6} at octave centre frequencies f_m

Relative sound power level for inlet side L_{Wrel5} at octave centre frequencies f_m

Speed
≤1800 1/min
Speed
>1800 1/min

63	125	250	500	1000	2000	4000	8000	Hz
-3	2	-4	-4	-5	-6	-14	-17	dB
63	125	250	500	1000	2000	4000	8000	Hz
-7	-8	-3	-2	-6	-8	-11	-17	dB

63	125	250	500	1000	2000	4000	8000	Hz
-2	4	-1	-4	-7	-9	-15	-17	dB
63	125	250	500	1000	2000	4000	8000	Hz
-6	-4	1	-1	-9	-12	-14	-17	dB

RLM ..-6371

Technical Data											
	Nominal motor power	Poles	Motor size	Motor voltage	Nominal frequency	Connection	Nominal motor current	Nominal motor speed	Max. fan speed	Max. operating frequency	Weight
RLM 56-	kW	-		V	Hz		A	1/min	1/min	Hz	kg
6371-6D-21	3.00	6	132 S	400	50	Δ	7.30	955	1110	58	123
6371-6D-23	4.00	6	132 M	400	50	Δ	9.30	950	1220	64	127
6371-6D-24	5.50	6	132 M	400	50	Δ	12.80	950	1350	71	136
6371-4D-23	7.50	4	132 M	400	50	Δ	15.40	1450	1510	52	130
6371-4D-26	11.00	4	160 M	400	50	Δ	22.00	1460	1710	58	154
6371-4D-28	15.00	4	160 L	400	50	Δ	30.00	1460	1880	64	178
6371-4D-30	18.50	4	180 M	400	50	Δ	35.50	1465	2020	69	241

Technical Data											
	Nominal motor power	Poles	Motor size	Motor voltage	Nominal frequency	Connection	Nominal motor current	Nominal motor speed	Max. fan speed	Max. operating frequency	Weight
RLM 56-Ex II 2G c IIB T4	kW	-		V	Hz		A	1/min	1/min	Hz	kg
6371-6Y-21-2G	3.00	6	132 S	400	50	Δ	7.40	945	1110	58	167
6371-6Y-23-2G	4.00	6	132 M	400	50	Δ	9.60	945	1220	64	173
6371-6Y-24-2G	5.50	6	132 M	400	50	Δ	12.60	950	1350	71	180
6371-4Y-23-2G	7.50	4	132 M	400	50	Δ	15.00	1450	1490	51	171
6371-4Y-26-2G	11.00	4	160 M	400	50	Δ	21.50	1455	1700	58	220
6371-4Y-28-2G	15.00	4	160 L	400	50	Δ	28.50	1455	1840	63	263

Dimensions in mm, subject to change.

RLM 56-6371

	k_{max}	w	y
132	839	692	592
160	934	791	691
180	963	845	745

Accessories

	Frequency Inverter Unit MM420 for 3~	Line Choke for 3~	Frequency Inverter 6SE6430-	Control Panel for Frequency Inverter 6SE6420- and 6SE6430-
RLM 56-				
6371-6D-21	MM420 3AC 400V 3.00KW EMV B	6SE6400-3CC01-0BD3	-	-
6371-6D-23	MM420 3AC 400V 4.00KW EMV B	6SE6400-3CC01-4BD3	-	-
6371-6D-24	MM420 3AC 400V 5.50KW EMV B	6SE6400-3CC02-2CD3	-	-
6371-4D-23	MM420 3AC 400V 7.50KW EMV B	6SE6400-3CC02-2CD3	-	-
6371-4D-26	MM420 3AC 400V 11.0KW EMV B	6SE6400-3CC03-5CD3	-	-
6371-4D-28	-	6SE6400-3CC03-5CD3	6SE6430-2AD31-5CA0	6SE6400-0BP00-0AA0
6371-4D-30	-	6SE6400-3CC04-4DD0	6SE6430-2AD31-8DA0	6SE6400-0BP00-0AA0
RLM 56-Ex II 2G c IIB T4				
6371-6Y-21-2G	MM420 3AC 400V 3.00KW EMV B	6SE6400-3CC01-0BD3	-	-
6371-6Y-23-2G	MM420 3AC 400V 4.00KW EMV B	6SE6400-3CC01-4BD3	-	-
6371-6Y-24-2G	MM420 3AC 400V 5.50KW EMV B	6SE6400-3CC02-2CD3	-	-
6371-4Y-23-2G	MM420 3AC 400V 7.50KW EMV B	6SE6400-3CC02-2CD3	-	-
6371-4Y-26-2G	MM420 3AC 400V 11.0KW EMV B	6SE6400-3CC03-5CD3	-	-
6371-4Y-28-2G	-	6SE6400-3CC03-5CD3	6SE6430-2AD31-5CA0	6SE6400-0BE00-0AA0

RLM ..-7180

Technical Data

Impeller Data

Impeller diameter	D_r	808 mm
Number of blades	z	6
Moment of Inertia	J	4.6 kgm ²

Impeller Data

Impeller weight	m	51 kg
Density of media	ρ_1	1.2 kg/m ³
Tolerance class (DIN 24166)		1

Technical Data

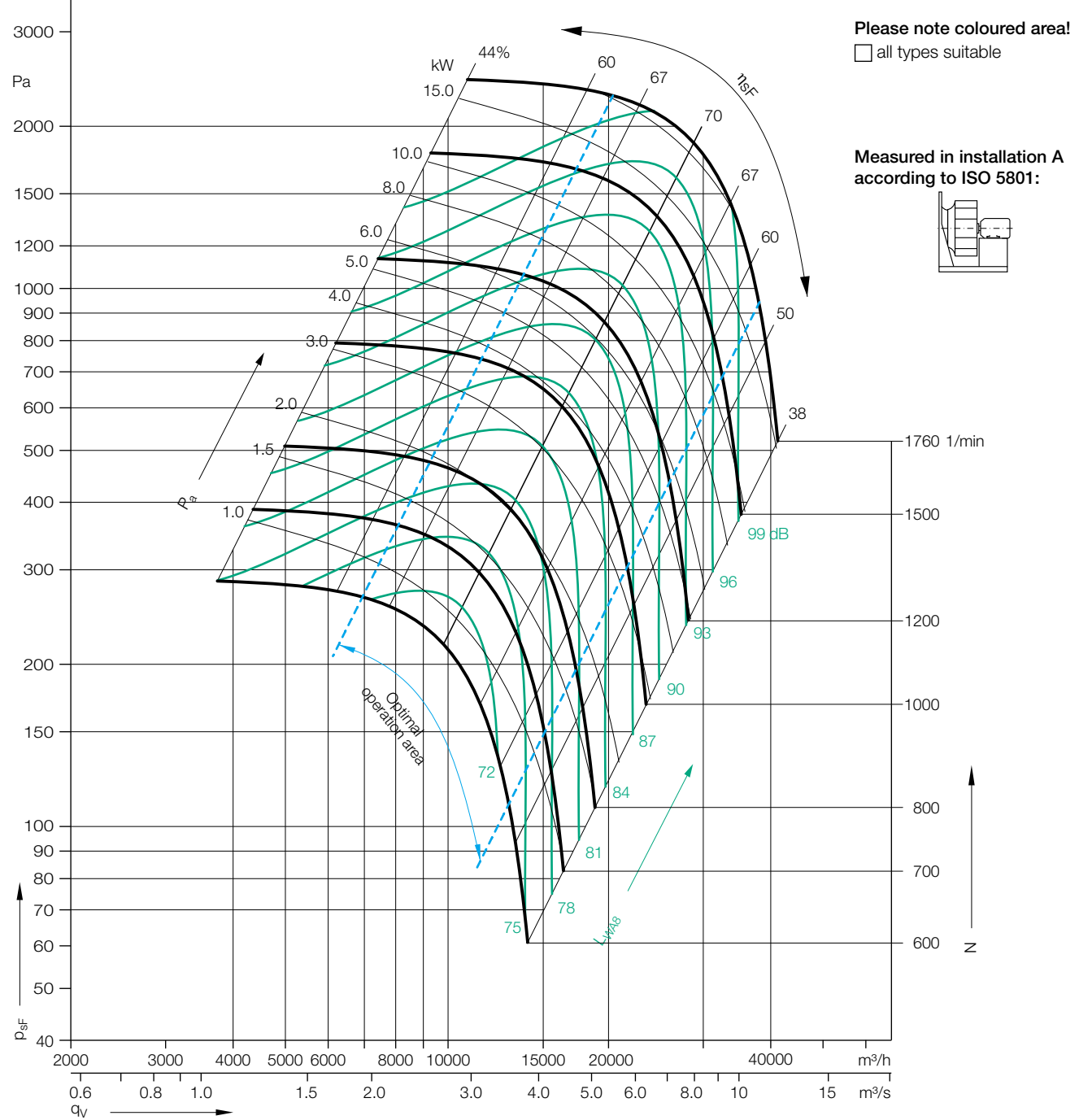

Relative sound power level for discharge side L_{Wrel6} at octave centre frequencies f_m

Relative sound power level for inlet side L_{Wrel5} at octave centre frequencies f_m

Speed
≤900 1/min
Speed
>900 1/min

63	125	250	500	1000	2000	4000	8000	Hz
7	0	-3	-3	-4	-9	-16	-20	dB
63	125	250	500	1000	2000	4000	8000	Hz
1	3	-3	-4	-4	-7	-15	-19	dB

63	125	250	500	1000	2000	4000	8000	Hz
6	2	-2	-3	-5	-11	-16	-22	dB
63	125	250	500	1000	2000	4000	8000	Hz
1	4	-1	-4	-6	-9	-14	-20	dB

RLM ..-7180

Technical Data											
	Nominal motor power	Poles	Motor size	Motor voltage	Nominal frequency	Connection	Nominal motor current	Nominal motor speed	Max. fan speed	Max. operating frequency	Weight
RLM 56-	kW	-		V	Hz		A	1/min	1/min	Hz	kg
7180-6D-23	4.00	6	132 M	400	50	Δ	9.30	950	1000	52	165
7180-6D-24	5.50	6	132 M	400	50	Δ	12.80	950	1110	58	174
7180-6D-26	7.50	6	160 M	400	50	Δ	17.60	970	1230	63	204
7180-6D-28	11.00	6	160 L	400	50	Δ	24.00	965	1380	71	229
7180-4D-28	15.00	4	160 L	400	50	Δ	30.00	1460	1550	53	211
7180-4D-30	18.50	4	180 M	400	50	Δ	35.50	1465	1650	56	274
7180-4D-31	22.00	4	180 L	400	50	Δ	42.00	1465	1760	60	289

Technical Data											
	Nominal motor power	Poles	Motor size	Motor voltage	Nominal frequency	Connection	Nominal motor current	Nominal motor speed	Max. fan speed	Max. operating frequency	Weight
RLM 56-Ex II 2G c IIB T4	kW	-		V	Hz		A	1/min	1/min	Hz	kg
7180-6Y-23-2G	4.00	6	132 M	400	50	Δ	9.60	945	990	52	211
7180-6Y-24-2G	5.50	6	132 M	400	50	Δ	12.60	950	1100	58	218
7180-6Y-26-2G	7.50	6	160 M	400	50	Δ	17.50	960	1230	64	266
7180-6Y-28-2G	11.00	6	160 L	400	50	Δ	24.50	960	1380	72	304
7180-4Y-28-2G	15.00	4	160 L	400	50	Δ	28.50	1455	1530	52	296
7180-4Y-30-2G	18.50	4	180 M	400	50	Δ	35.00	1460	1600	54	309

Dimensions in mm, subject to change.

RLM 56-7180

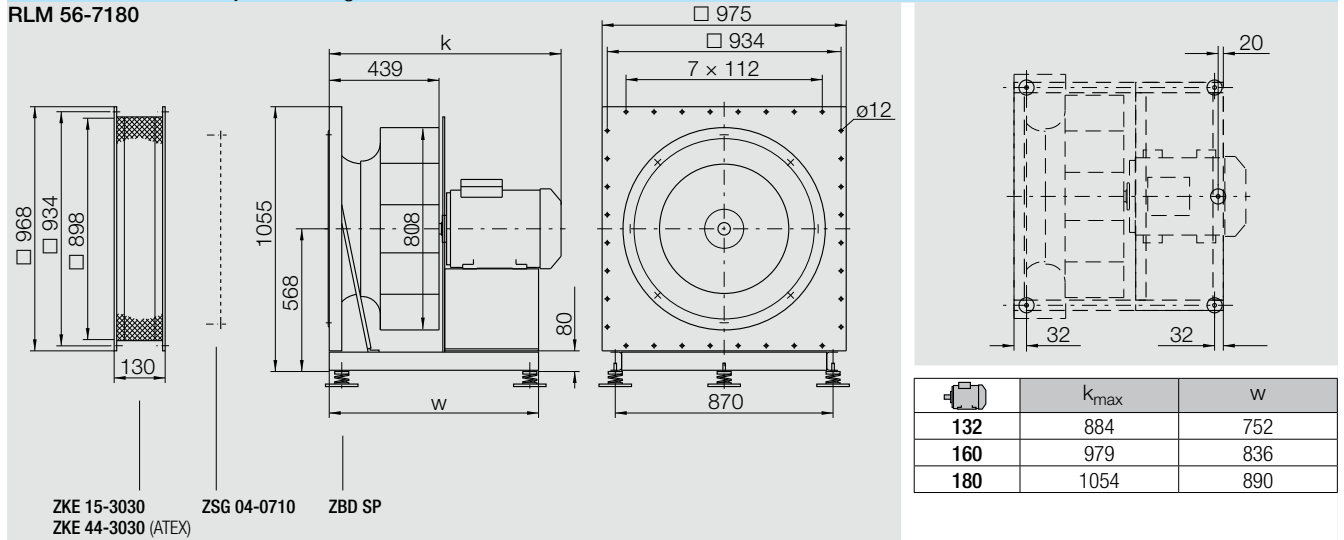

Accessories

	Frequency Inverter Unit MM420 for 3~	Line Choke for 3~	Frequency Inverter 6SE6430-	Control Panel for Frequency Inverter 6SE6420- and 6SE6430-
RLM 56-				
7180-6D-23	MM420 3AC 400V 4.00KW EMV B	6SE6400-3CC01-4BD3	-	-
7180-6D-24	MM420 3AC 400V 5.50KW EMV B	6SE6400-3CC02-2CD3	-	-
7180-6D-26	MM420 3AC 400V 7.50KW EMV B	6SE6400-3CC02-2CD3	-	-
7180-6D-28	MM420 3AC 400V 11.0KW EMV B	6SE6400-3CC03-5CD3	-	-
7180-4D-28	-	6SE6400-3CC03-5CD3	6SE6430-2AD31-5CA0	6SE6400-0BP00-0AA0
7180-4D-30	-	6SE6400-3CC04-4DD0	6SE6430-2AD31-8DA0	6SE6400-0BP00-0AA0
7180-4D-31	-	6SE6400-3CC04-4DD0	6SE6430-2AD32-2DA0	6SE6400-0BP00-0AA0
RLM 56-Ex II 2G c IIB T4				
7180-6Y-23-2G	MM420 3AC 400V 4.00KW EMV B	6SE6400-3CC01-4BD3	-	-
7180-6Y-24-2G	MM420 3AC 400V 5.50KW EMV B	6SE6400-3CC02-2CD3	-	-
7180-6Y-26-2G	MM420 3AC 400V 7.50KW EMV B	6SE6400-3CC02-2CD3	-	-
7180-6Y-28-2G	MM420 3AC 400V 11.0KW EMV B	6SE6400-3CC03-5CD3	-	-
7180-4Y-28-2G	-	6SE6400-3CC03-5CD3	6SE6430-2AD31-5CA0	6SE6400-0BE00-0AA0
7180-4Y-30-2G	-	6SE6400-3CC04-4DD0	6SE6430-2AD31-8DA0	6SE6400-0BE00-0AA0

RLM ..-8090

Technical Data

Impeller Data

Impeller diameter	D_r	905 mm
Number of blades	z	6
Moment of Inertia	J	8.4 kgm ²

Impeller Data

Impeller weight	m	74 kg
Density of media	ρ_1	1.2 kg/m ³
Tolerance class (DIN 24166)		1

Technical Data

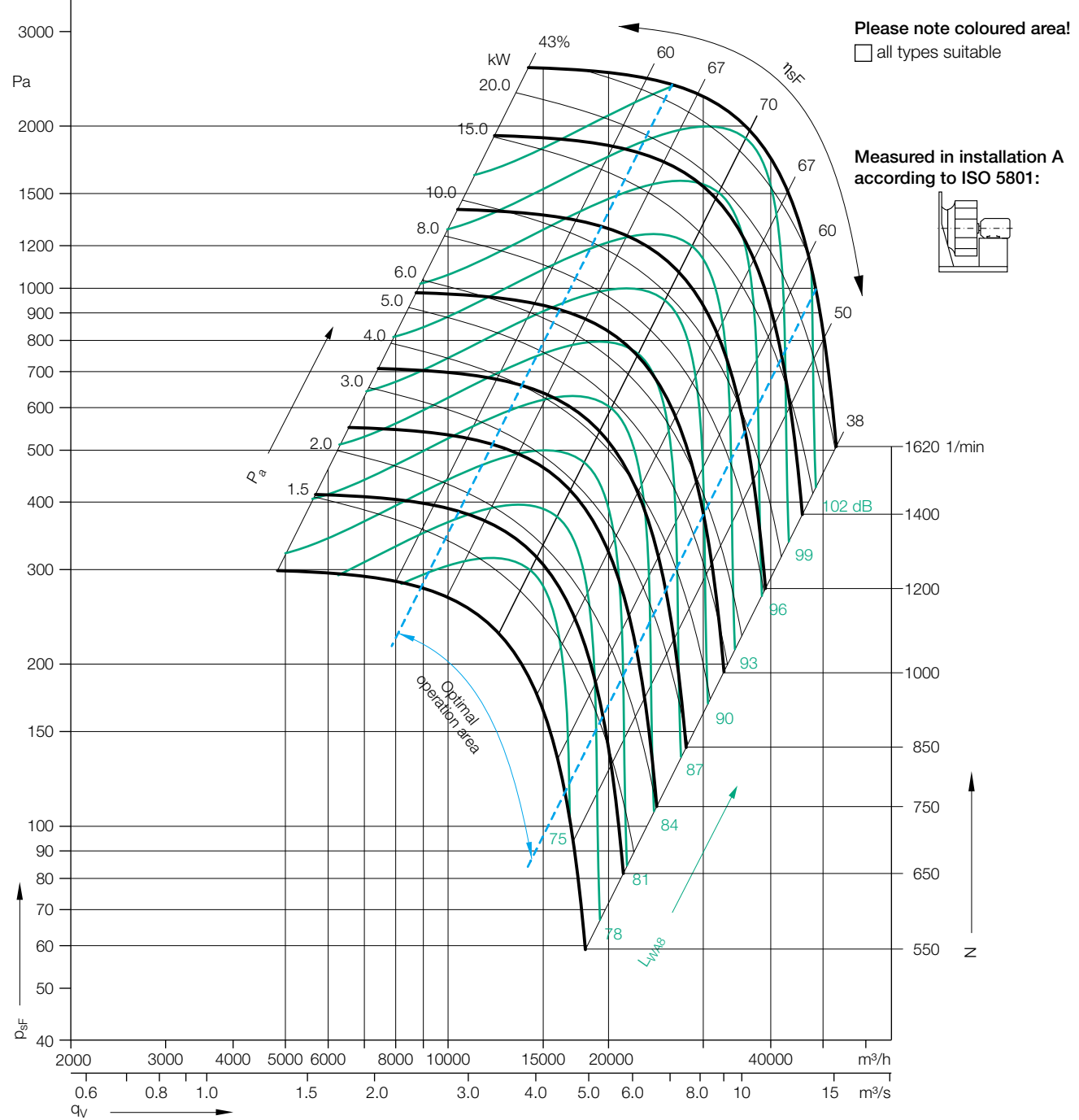

Relative sound power level for discharge side L_{Wrel6} at octave centre frequencies f_m

Relative sound power level for inlet side L_{Wrel5} at octave centre frequencies f_m

Speed
≤900 1/min
Speed
>900 1/min

63	125	250	500	1000	2000	4000	8000	Hz
7	0	-3	-3	-4	-9	-16	-20	dB
63	125	250	500	1000	2000	4000	8000	Hz
1	3	-3	-4	-4	-7	-15	-19	dB

63	125	250	500	1000	2000	4000	8000	Hz
10	5	-1	-3	-5	-11	-16	-22	dB
63	125	250	500	1000	2000	4000	8000	Hz
5	7	0	-4	-6	-9	-14	-20	dB

RLM ..-8090

Technical Data											
	Nominal motor power	Poles	Motor size	Motor voltage	Nominal frequency	Connection	Nominal motor current	Nominal motor speed	Max. fan speed	Max. operating frequency	Weight
	kW	-		V	Hz		A	1/min	1/min	Hz	kg
RLM 56-											
8090-8D-26	4.00	8	160 M	400	50	Δ	10.00	715	830	58	228
8090-8D-27	5.50	8	160 M	400	50	Δ	13.00	710	930	65	237
8090-6D-26	7.50	6	160 M	400	50	Δ	17.60	970	1030	53	241
8090-6D-28	11.00	6	160 L	400	50	Δ	24.00	965	1160	60	266
8090-6D-31	15.00	6	180 L	400	50	Δ	29.50	965	1280	66	322
8090-6D-33	18.50	6	200 L	400	50	Δ	37.00	975	1380	71	371
8090-4D-31	22.00	4	180 L	400	50	Δ	42.00	1465	1465	50	327
8090-4D-34	30.00	4	200 L	400	50	Δ	56.00	1465	1620	55	386

Technical Data											
	Nominal motor power	Poles	Motor size	Motor voltage	Nominal frequency	Connection	Nominal motor current	Nominal motor speed	Max. fan speed	Max. operating frequency	Weight
	kW	-		V	Hz		A	1/min	1/min	Hz	kg
RLM 56-Ex II 2G c IIB T4											
8090-8Y-26-2G	4.00	8	160 M	400	50	Δ	9.90	715	820	57	283
8090-8Y-27-2G	5.50	8	160 M	400	50	Δ	13.30	710	920	64	297
8090-6Y-26-2G	7.50	6	160 M	400	50	Δ	17.50	960	1010	52	303
8090-6Y-28-2G	11.00	6	160 L	400	50	Δ	24.50	960	1150	59	341
8090-6Y-31-2G	15.00	6	180 L	400	50	Δ	29.50	970	1280	66	362
8090-6Y-33-2G	18.50	6	200 L	400	50	Δ	36.00	975	1380	70	416
8090-4Y-31-2G	22.00	4	180 L	400	50	Δ	41.00	1460	1440	49	361
8090-4Y-34-2G	30.00	4	200 L	400	50	Δ	55.00	1465	1540	52	428

Dimensions in mm, subject to change.

RLM 56-8090

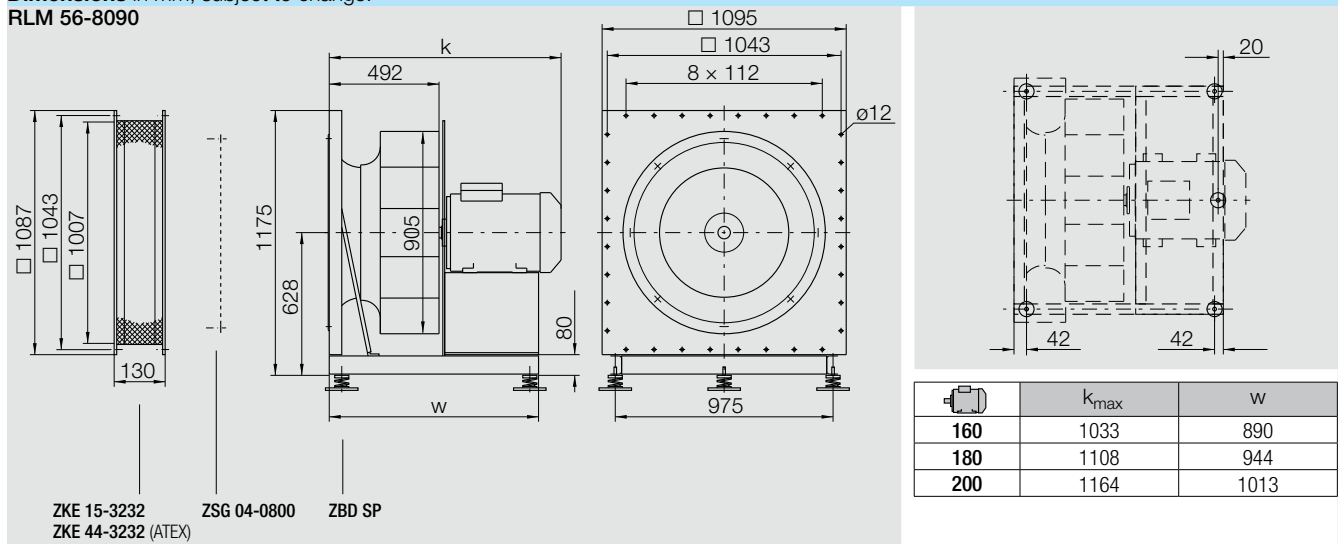

Accessories

	Frequency Inverter Unit MM420 for 3~	Line Choke for 3~	Frequency Inverter 6SE6430-	Control Panel for Frequency Inverter 6SE6420- and 6SE6430-
RLM 56-				
8090-8D-26	MM420 3AC 400V 4.00KW EMV B	6SE6400-3CC01-4BD3	-	-
8090-8D-27	MM420 3AC 400V 5.50KW EMV B	6SE6400-3CC02-2CD3	-	-
8090-6D-26	MM420 3AC 400V 7.50KW EMV B	6SE6400-3CC02-2CD3	-	-
8090-6D-28	MM420 3AC 400V 11.0KW EMV B	6SE6400-3CC03-5CD3	-	-
8090-6D-31	-	6SE6400-3CC03-5CD3	6SE6430-2AD31-5CA0	6SE6400-0BP00-0AA0
8090-6D-33	-	6SE6400-3CC04-4DD0	6SE6430-2AD31-8DA0	6SE6400-0BP00-0AA0
8090-4D-31	-	6SE6400-3CC04-4DD0	6SE6430-2AD32-2DA0	6SE6400-0BP00-0AA0
8090-4D-34	-	6SE6400-3CC05-2DD0	6SE6430-2AD33-0DA0	6SE6400-0BP00-0AA0
RLM 56-Ex II 2G c IIB T4				
8090-8Y-26-2G	MM420 3AC 400V 4.00KW EMV B	6SE6400-3CC01-4BD3	-	-
8090-8Y-27-2G	MM420 3AC 400V 5.50KW EMV B	6SE6400-3CC02-2CD3	-	-
8090-6Y-26-2G	MM420 3AC 400V 7.50KW EMV B	6SE6400-3CC02-2CD3	-	-
8090-6Y-28-2G	MM420 3AC 400V 11.0KW EMV B	6SE6400-3CC03-5CD3	-	-
8090-6Y-31-2G	-	6SE6400-3CC03-5CD3	6SE6430-2AD31-5CA0	6SE6400-0BE00-0AA0
8090-6Y-33-2G	-	6SE6400-3CC04-4DD0	6SE6430-2AD31-8DA0	6SE6400-0BE00-0AA0
8090-4Y-31-2G	-	6SE6400-3CC04-4DD0	6SE6430-2AD32-2DA0	6SE6400-0BE00-0AA0
8090-4Y-34-2G	-	6SE6400-3CC05-2DD0	6SE6430-2AD33-0DA0	6SE6400-0BE00-0AA0

RLM ..-9010

Technical Data

Impeller Data

Impeller diameter	D_r	995 mm
Number of blades	z	6
Moment of Inertia	J	12.5 kgm ²

Impeller Data

Impeller weight	m	88 kg
Density of media	ρ_1	1.2 kg/m ³
Tolerance class (DIN 24166)		1

Technical Data

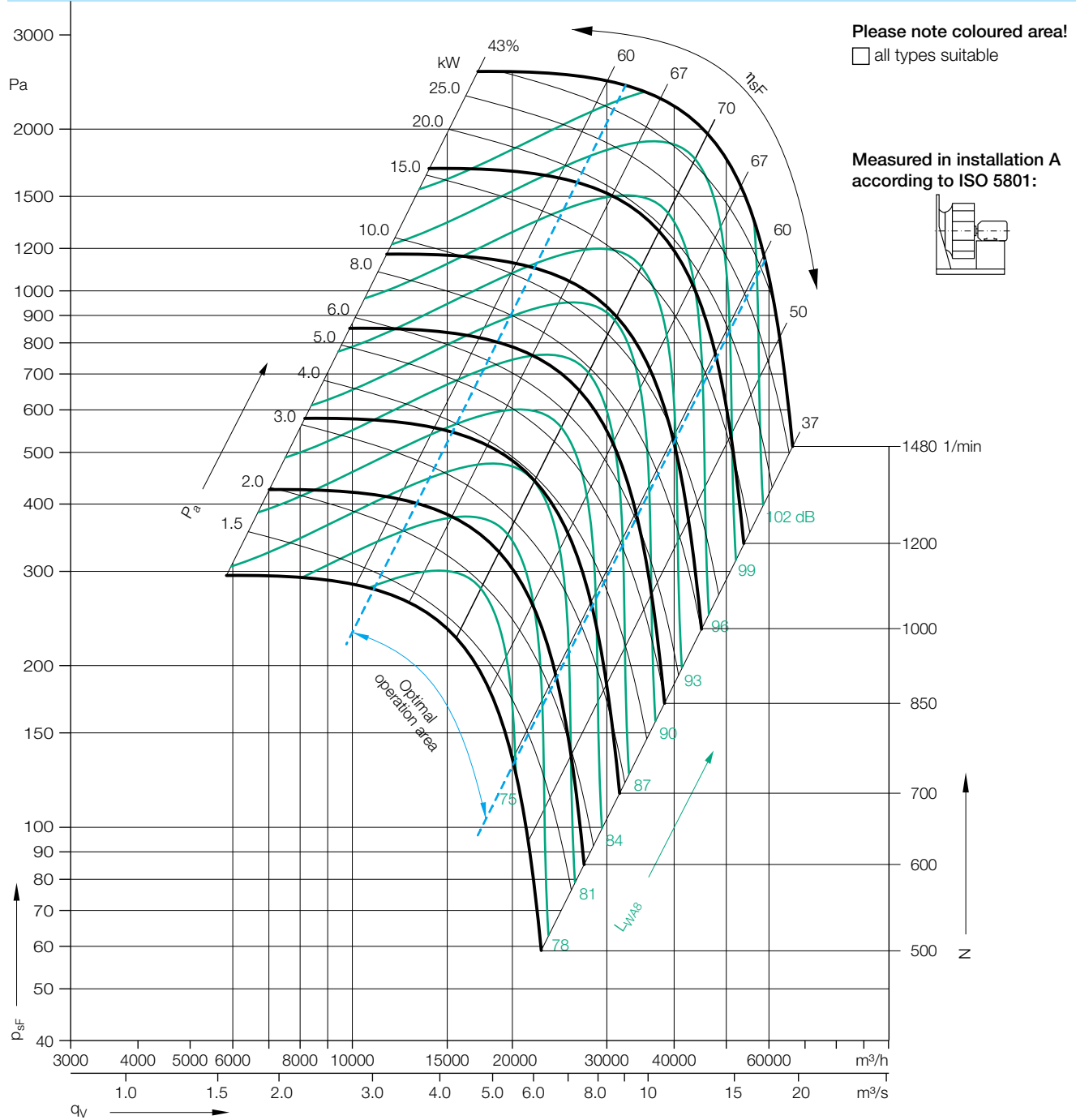

Relative sound power level for discharge side L_{Wrel6} at octave centre frequencies f_m

Speed	63	125	250	500	1000	2000	4000	8000	Hz
≤900 1/min	7	0	-3	-3	-4	-9	-16	-20	dB
Speed	63	125	250	500	1000	2000	4000	8000	Hz
>900 1/min	1	3	-3	-4	-4	-7	-15	-19	dB

Relative sound power level for inlet side L_{Wrel5} at octave centre frequencies f_m

Speed	63	125	250	500	1000	2000	4000	8000	Hz
≤900 1/min	10	5	-1	-3	-5	-11	-16	-22	dB
Speed	63	125	250	500	1000	2000	4000	8000	Hz
>900 1/min	5	7	0	-4	-6	-9	-14	-20	dB

RLM ..-9010

Technical Data											
	Nominal motor power	Poles	Motor size	Motor voltage	Nominal frequency	Connection	Nominal motor current	Nominal motor speed	Max. fan speed	Max. operating frequency	Weight
	kW	-		V	Hz		A	1/min	1/min	Hz	kg
RLM 56-											
9010-8D-27	5.50	8	160 M	400	50	Δ	13.00	710	780	55	274
9010-8D-28	7.50	8	160 L	400	50	Δ	17.60	715	860	60	295
9010-6D-28	11.00	6	160 L	400	50	Δ	24.00	965	980	51	303
9010-6D-31	15.00	6	180 L	400	50	Δ	29.50	965	1080	56	354
9010-6D-33	18.50	6	200 L	400	50	Δ	37.00	975	1170	60	400
9010-6D-34	22.00	6	200 L	400	50	Δ	44.00	975	1250	64	410
9010-6D-37	30.00	6	225 M	400	50	Δ	58.00	978	1360	69	485
9010-4D-36	37.00	4	225 S	400	50	Δ	69.00	1475	1480	50	480

Technical Data											
	Nominal motor power	Poles	Motor size	Motor voltage	Nominal frequency	Connection	Nominal motor current	Nominal motor speed	Max. fan speed	Max. operating frequency	Weight
	kW	-		V	Hz		A	1/min	1/min	Hz	kg
RLM 56-Ex II 2G c IIB T4											
9010-8Y-27-2G	5.50	8	160 M	400	50	Δ	13.30	710	770	54	334
9010-8Y-28-2G	7.50	8	160 L	400	50	Δ	17.90	715	860	60	360
9010-6Y-28-2G	11.00	6	160 L	400	50	Δ	24.50	960	970	50	378
9010-6Y-31-2G	15.00	6	180 L	400	50	Δ	29.50	970	1080	55	394
9010-6Y-33-2G	18.50	6	200 L	400	50	Δ	36.00	975	1160	59	445
9010-6Y-34-2G	22.00	6	200 L	400	50	Δ	42.50	975	1230	63	460
9010-6Y-37-2G	30.00	6	225 M	400	50	Δ	56.00	978	1360	69	535

Dimensions in mm, subject to change.

RLM 56-9010

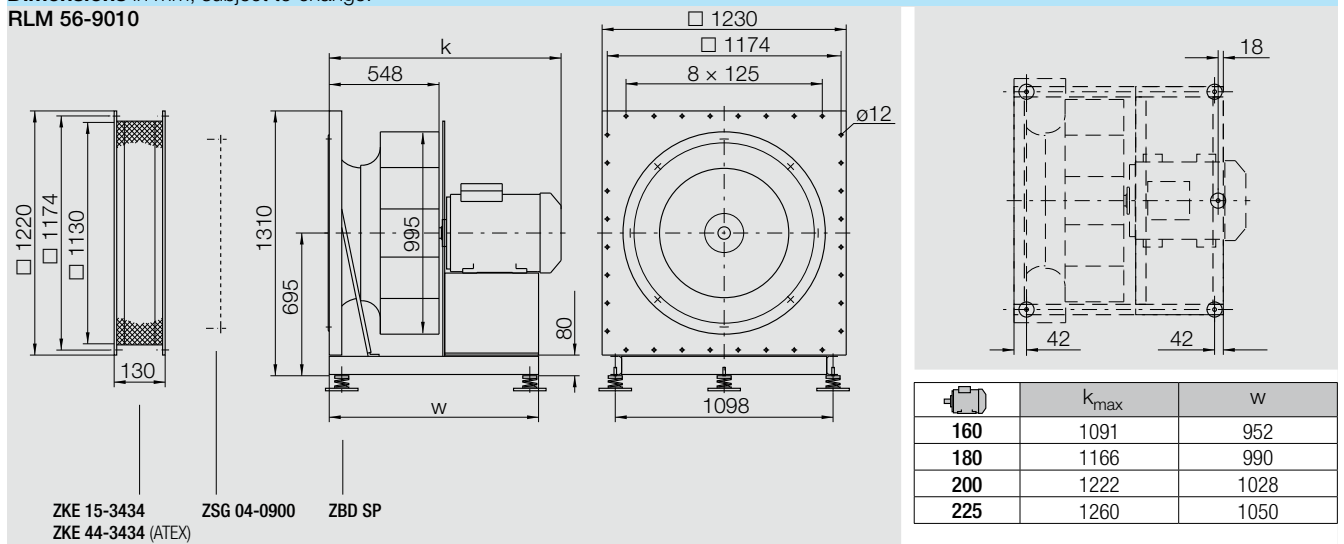

Accessories

	Frequency Inverter Unit MM420 for 3~	Line Choke for 3~	Frequency Inverter 6SE6430-	Control Panel for Frequency Inverter 6SE6420- and 6SE6430-
RLM 56-				
9010-8D-27	MM420 3AC 400V 5.50KW EMV B	6SE6400-3CC02-2CD3	-	-
9010-8D-28	MM420 3AC 400V 7.50KW EMV B	6SE6400-3CC02-2CD3	-	-
9010-6D-28	MM420 3AC 400V 11.0KW EMV B	6SE6400-3CC03-5CD3	-	-
9010-6D-31	-	6SE6400-3CC03-5CD3	6SE6430-2AD31-5CA0	6SE6400-0BP00-0AA0
9010-6D-33	-	6SE6400-3CC04-4DD0	6SE6430-2AD31-8DA0	6SE6400-0BP00-0AA0
9010-6D-34	-	6SE6400-3CC04-4DD0	6SE6430-2AD32-2DA0	6SE6400-0BP00-0AA0
9010-6D-37	-	6SE6400-3CC05-2DD0	6SE6430-2AD33-0DA0	6SE6400-0BP00-0AA0
9010-4D-36	-	6SE6400-3CC08-3ED0	6SE6430-2AD33-7EA0	6SE6400-0BP00-0AA0
RLM 56-Ex II 2G c IIB T4				
9010-8Y-27-2G	MM420 3AC 400V 5.50KW EMV B	6SE6400-3CC02-2CD3	-	-
9010-8Y-28-2G	MM420 3AC 400V 7.50KW EMV B	6SE6400-3CC02-2CD3	-	-
9010-6Y-28-2G	MM420 3AC 400V 11.0KW EMV B	6SE6400-3CC03-5CD3	-	-
9010-6Y-31-2G	-	6SE6400-3CC03-5CD3	6SE6430-2AD31-5CA0	6SE6400-0BE00-0AA0
9010-6Y-33-2G	-	6SE6400-3CC04-4DD0	6SE6430-2AD31-8DA0	6SE6400-0BE00-0AA0
9010-6Y-34-2G	-	6SE6400-3CC04-4DD0	6SE6430-2AD32-2DA0	6SE6400-0BE00-0AA0
9010-6Y-37-2G	-	6SE6400-3CC05-2DD0	6SE6430-2AD33-0DA0	6SE6400-0BE00-0AA0

RLM ..-1011

Technical Data

Impeller Data

Impeller diameter	D_r	1120 mm
Number of blades	z	6
Moment of Inertia	J	22 kgm ²

Impeller Data

Impeller weight	m	146 kg
Density of media	ρ_1	1.2 kg/m ³
Tolerance class (DIN 24166)		1

Technical Data

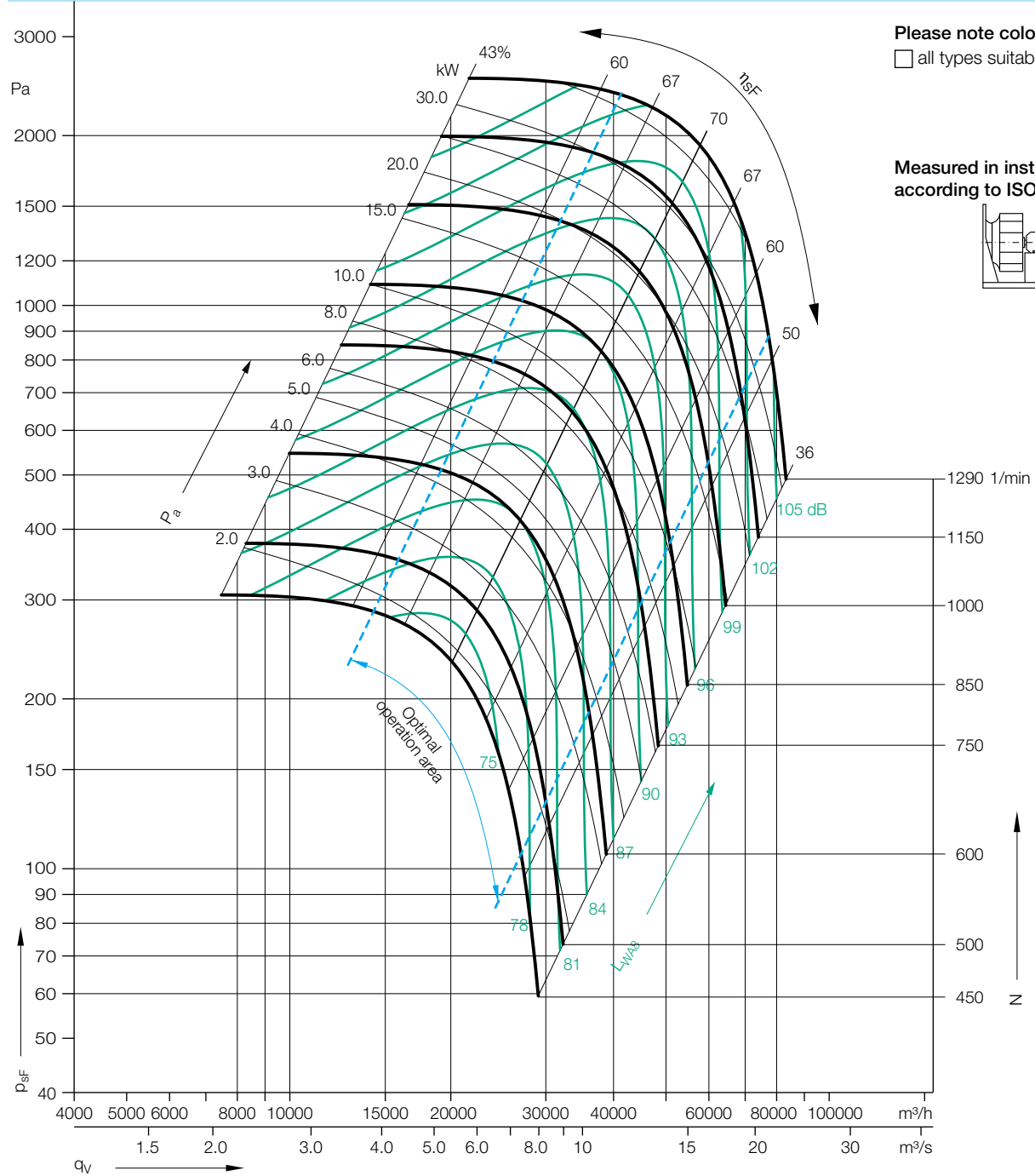

Please note coloured area!

all types suitable

Measured in installation A according to ISO 5801:

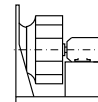

Relative sound power level for discharge side L_{Wrel6} at octave centre frequencies f_m

Speed	63	125	250	500	1000	2000	4000	8000	Hz
≤900 1/min	7	0	-3	-3	-4	-9	-16	-20	dB
Speed	63	125	250	500	1000	2000	4000	8000	Hz
>900 1/min	1	3	-3	-4	-4	-7	-15	-19	dB

Relative sound power level for inlet side L_{Wrel5} at octave centre frequencies f_m

Speed	63	125	250	500	1000	2000	4000	8000	Hz
≤900 1/min	10	5	-1	-3	-5	-11	-16	-22	dB
Speed	63	125	250	500	1000	2000	4000	8000	Hz
>900 1/min	5	7	0	-4	-6	-9	-14	-20	dB

RLM ..-1011

Technical Data											
	Nominal motor power	Poles	Motor size	Motor voltage	Nominal frequency	Connection	Nominal motor current	Nominal motor speed	Max. fan speed	Max. operating frequency	Weight
RLM 56-	kW	-		V	Hz		A	1/min	1/min	Hz	kg
1011-8D-31	11.00	8	180 L	400	50	Δ	25.00	725	810	56	446
1011-8D-33	15.00	8	200 L	400	50	Δ	32.50	725	900	62	502
1011-8D-36	18.50	8	225 S	400	50	Δ	38.50	730	960	66	567
1011-6D-34	22.00	6	200 L	400	50	Δ	44.00	975	1020	52	502
1011-6D-37	30.00	6	225 M	400	50	Δ	58.00	978	1130	58	577
1011-6D-39	37.00	6	250 M	400	50	Δ	71.00	980	1210	61	696
1011-6D-41	45.00	6	280 S	400	50	Δ	84.00	985	1290	65	805

Technical Data											
	Nominal motor power	Poles	Motor size	Motor voltage	Nominal frequency	Connection	Nominal motor current	Nominal motor speed	Max. fan speed	Max. operating frequency	Weight
RLM 56-Ex II 2G c IIB T4	kW	-		V	Hz		A	1/min	1/min	Hz	kg
1011-8Y-31-2G	11.00	8	180 L	400	50	Δ	26.00	725	800	55	487
1011-8Y-34-2G	15.00	8	200 L	400	50	Δ	32.00	725	890	61	560
1011-8Y-36-2G	18.50	8	225 S	400	50	Δ	37.50	725	950	65	622
1011-6Y-34-2G	22.00	6	200 L	400	50	Δ	42.50	975	1005	51	552
1011-6Y-37-2G	30.00	6	225 M	400	50	Δ	56.00	978	1120	57	627
1011-6Y-39-2G	37.00	6	250 M	400	50	Δ	69.00	980	1200	61	766
1011-6Y-41-2G	45.00	6	280 S	400	50	Δ	81.00	982	1285	65	890

Dimensions in mm, subject to change.

RLM 56-1011

	k_{max}	w	y5	g	h	h1
180	1236	1065	332	100	1460	780
200	1291	1102	357	100	1460	780
225	1330	1129	372	100	1460	780
250	1423	1187	412	120	1480	800
280	1500	1279	482	120	1480	800

Accessories

	Frequency Inverter Unit MM420 for 3~	Line Choke for 3~	Frequency Inverter 6SE6430-	Control Panel for Frequency Inverter 6SE6420- and 6SE6430-
RLM 56-				
1011-8D-31	MM420 3AC 400V 11.0KW EMV B	6SE6400-3CC03-5CD3	-	-
1011-8D-33	-	6SE6400-3CC03-5CD3	6SE6430-2AD31-5CA0	6SE6400-0BE00-0AA0
1011-8D-36	-	6SE6400-3CC04-4DD0	6SE6430-2AD31-8DA0	6SE6400-0BE00-0AA0
1011-6D-34	-	6SE6400-3CC04-4DD0	6SE6430-2AD32-2DA0	6SE6400-0BE00-0AA0
1011-6D-37	-	6SE6400-3CC05-2DD0	6SE6430-2AD33-0DA0	6SE6400-0BE00-0AA0
1011-6D-39	-	6SE6400-3CC08-3ED0	6SE6430-2AD33-7EA0	6SE6400-0BE00-0AA0
1011-6D-41	-	6SE6400-3CC08-3ED0	6SE6430-2AD34-5EA0	6SE6400-0BE00-0AA0
RLM 56-Ex II 2G c IIB T4				
1011-8Y-31-2G	MM420 3AC 400V 11.0KW EMV B	6SE6400-3CC03-5CD3	-	-
1011-8Y-34-2G	-	6SE6400-3CC03-5CD3	6SE6430-2AD31-5CA0	6SE6400-0BE00-0AA0
1011-8Y-36-2G	-	6SE6400-3CC04-4DD0	6SE6430-2AD31-8DA0	6SE6400-0BE00-0AA0
1011-6Y-34-2G	-	6SE6400-3CC04-4DD0	6SE6430-2AD32-2DA0	6SE6400-0BE00-0AA0
1011-6Y-37-2G	-	6SE6400-3CC05-2DD0	6SE6430-2AD33-0DA0	6SE6400-0BE00-0AA0
1011-6Y-39-2G	-	6SE6400-3CC08-3ED0	6SE6430-2AD33-7EA0	6SE6400-0BE00-0AA0
1011-6Y-41-2G	-	6SE6400-3CC08-3ED0	6SE6430-2AD34-5EA0	6SE6400-0BE00-0AA0

RLM ..-1112

Technical Data

Impeller Data

Impeller diameter	D_r	1250	mm
Number of blades	z	6	
Moment of Inertia	J	29.6	kgm ²

Impeller Data

Impeller weight	m	160	kg
Density of media	ρ_1	1.2	kg/m ³
Tolerance class (DIN 24166)		1	

Technical Data

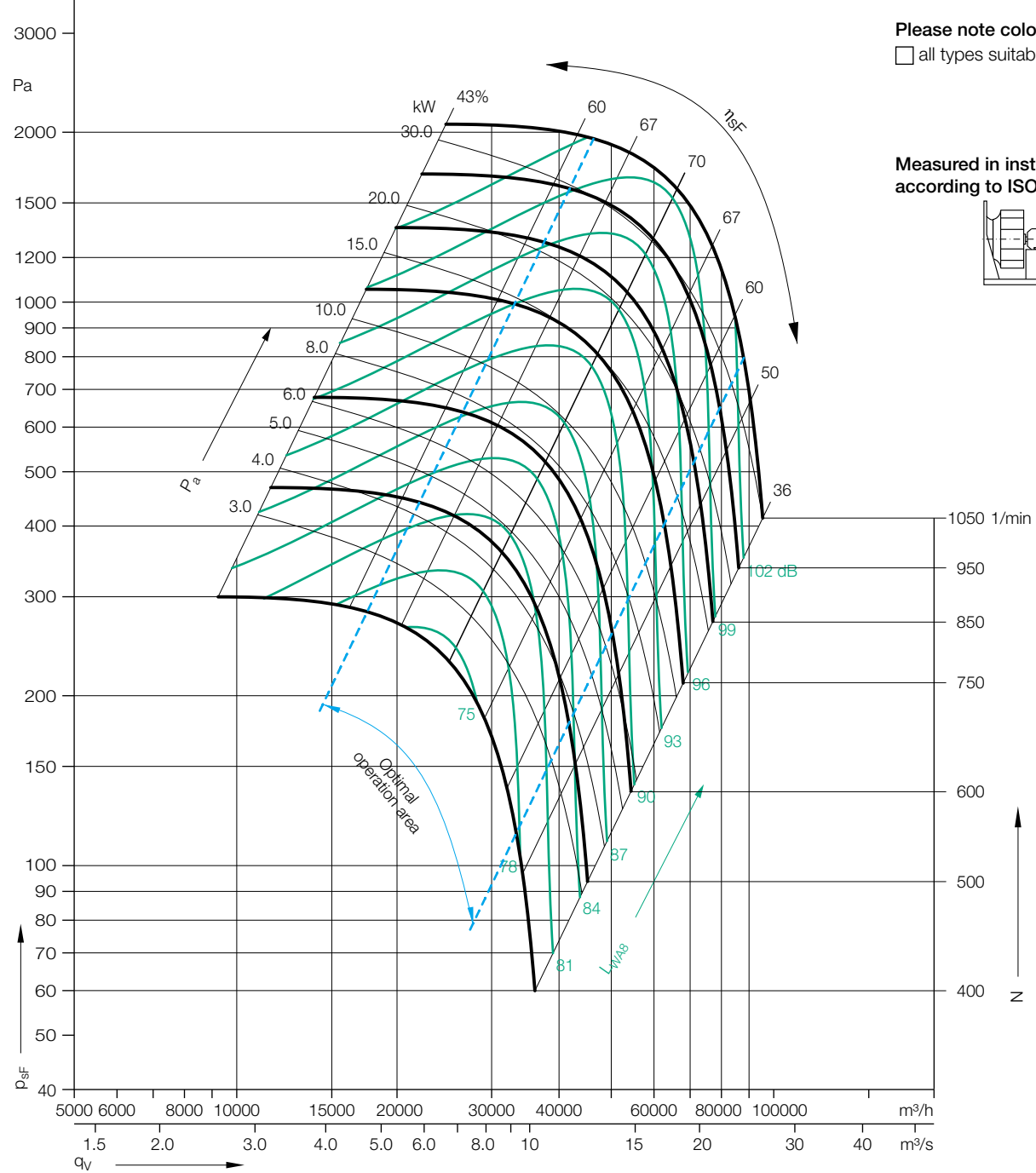

Please note coloured area!

all types suitable

Measured in installation A according to ISO 5801:

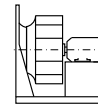

Relative sound power level for discharge side L_{Wrel8} at octave centre frequencies f_m

Speed	63	125	250	500	1000	2000	4000	8000	Hz
≤900 1/min	7	0	-3	-3	-4	-9	-16	-20	dB
Speed	63	125	250	500	1000	2000	4000	8000	Hz
>900 1/min	1	3	-3	-4	-4	-7	-15	-19	dB

Relative sound power level for inlet side L_{Wrel5} at octave centre frequencies f_m

Speed	63	125	250	500	1000	2000	4000	8000	Hz
≤900 1/min	10	5	-1	-3	-5	-11	-16	-22	dB
Speed	63	125	250	500	1000	2000	4000	8000	Hz
>900 1/min	5	7	0	-4	-6	-9	-14	-20	dB

RLM ..-1112

Technical Data											
	Nominal motor power	Poles	Motor size	Motor voltage	Nominal frequency	Connection	Nominal motor current	Nominal motor speed	Max. fan speed	Max. operating frequency	Weight
RLM 55-	kW	-		V	Hz		A	1/min	1/min	Hz	kg
1112-8D-33	15.00	8	200 L	400	50	Δ	32.50	725	750	52	603
1112-8D-36	18.50	8	225 S	400	50	Δ	38.50	730	800	55	721
1112-8D-37	22.00	8	225 M	400	50	Δ	45.00	730	850	58	746
1112-8D-39	30.00	8	250 M	400	50	Δ	58.00	730	940	64	856
1112-6D-39	37.00	6	250 M	400	50	Δ	71.00	980	1010	51	831
1112-6D-41	45.00	6	280 S	400	50	Δ	84.00	985	1050	53	965

Technical Data											
	Nominal motor power	Poles	Motor size	Motor voltage	Nominal frequency	Connection	Nominal motor current	Nominal motor speed	Max. fan speed	Max. operating frequency	Weight
RLM 55-Ex II 2G c IIB T4	kW	-		V	Hz		A	1/min	1/min	Hz	kg
1112-8Y-34-2G	15.00	8	200 L	400	50	Δ	32.00	725	740	51	661
1112-8Y-36-2G	18.50	8	225 S	400	50	Δ	37.50	725	790	54	776
1112-8Y-37-2G	22.00	8	225 M	400	50	Δ	43.50	725	840	58	806
1112-8Y-39-2G	30.00	8	250 M	400	50	Δ	58.00	730	930	63	936

Dimensions in mm, subject to change.

RLM 56-1112

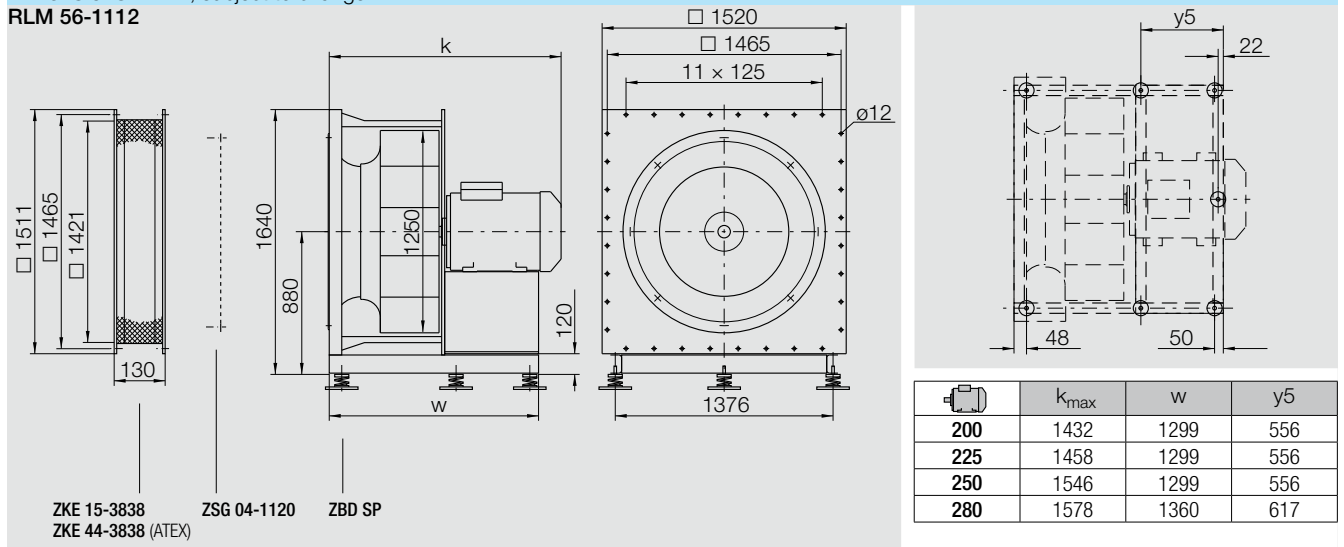

Accessories

	Frequency Inverter 6SE6430-	Control Panel for Frequency Inverter 6SE6420- and 6SE6430-	Line Choke for 3~
RLM 55-			
1112-8D-33	6SE6430-2AD31-5CA0	6SE6400-0BE00-0AA0	6SE6400-3CC03-5CD3
1112-8D-36	6SE6430-2AD31-8DA0	6SE6400-0BE00-0AA0	6SE6400-3CC04-4DD0
1112-8D-37	6SE6430-2AD32-2DA0	6SE6400-0BE00-0AA0	6SE6400-3CC04-4DD0
1112-8D-39	6SE6430-2AD33-0DA0	6SE6400-0BE00-0AA0	6SE6400-3CC05-2DD0
1112-6D-39	6SE6430-2AD33-7EA0	6SE6400-0BE00-0AA0	6SE6400-3CC08-3ED0
1112-6D-41	6SE6430-2AD34-5EA0	6SE6400-0BE00-0AA0	6SE6400-3CC08-3ED0
RLM 55-Ex II 2G c IIB T4			
1112-8Y-34-2G	6SE6430-2AD31-5CA0	6SE6400-0BE00-0AA0	6SE6400-3CC03-5CD3
1112-8Y-36-2G	6SE6430-2AD31-8DA0	6SE6400-0BE00-0AA0	6SE6400-3CC04-4DD0
1112-8Y-37-2G	6SE6430-2AD32-2DA0	6SE6400-0BE00-0AA0	6SE6400-3CC04-4DD0
1112-8Y-39-2G	6SE6430-2AD33-0DA0	6SE6400-0BE00-0AA0	6SE6400-3CC05-2DD0

RLM ..-1214

Technical Data

Impeller Data

Impeller diameter	D_r	1400	mm
Number of blades	z	6	
Moment of Inertia	J	41	kgm ²

Impeller Data

Impeller weight	m	191	kg
Density of media	ρ_1	1.2	kg/m ³
Tolerance class (DIN 24166)		1	

Technical Data

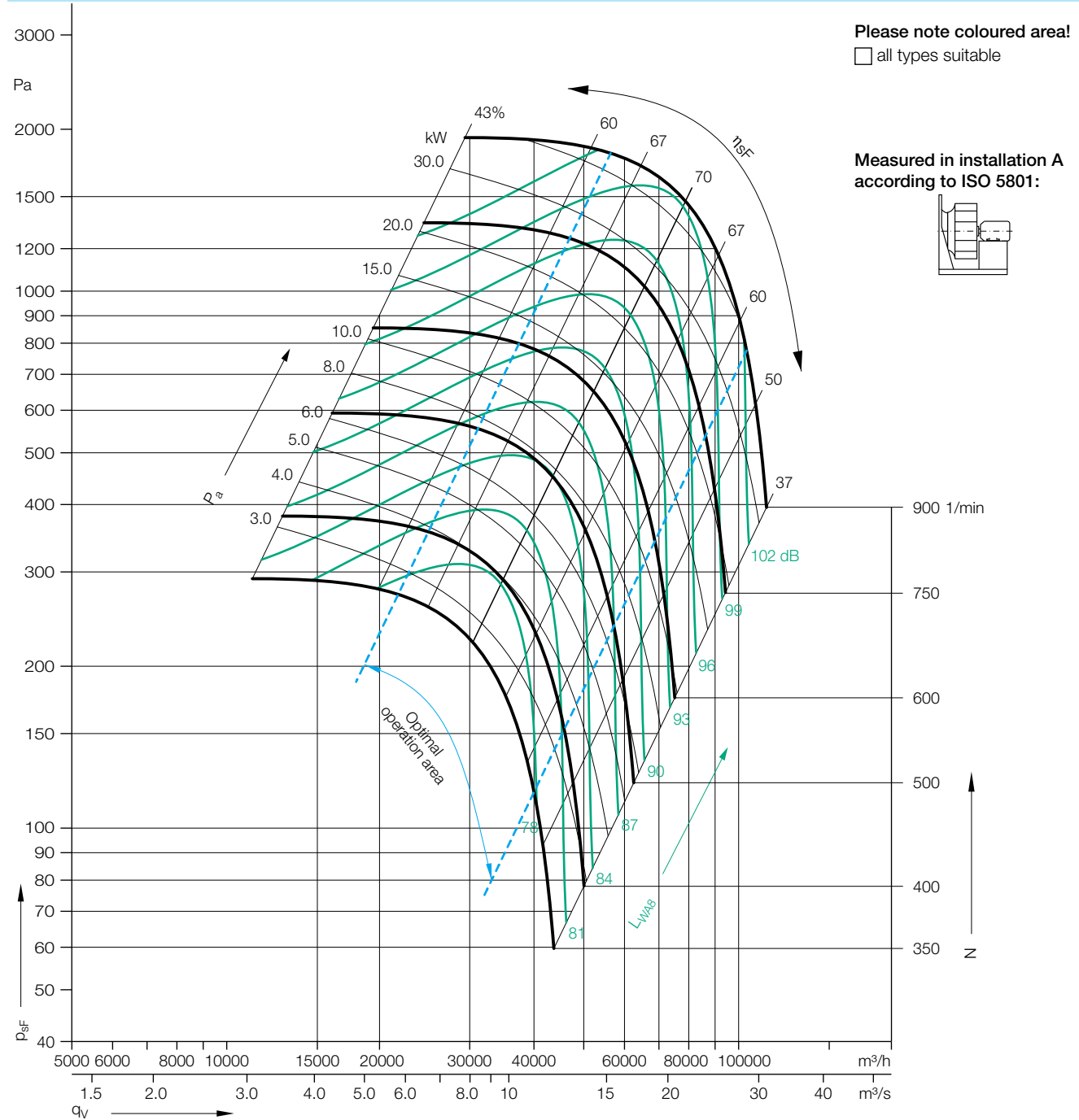

Relative sound power level for discharge side L_{WrelB} at octave centre frequencies f_m

Relative sound power level for inlet side L_{WrelS} at octave centre frequencies f_m

Speed
≤900 1/min
Speed
>900 1/min

63	125	250	500	1000	2000	4000	8000	Hz
7	0	-3	-3	-4	-9	-16	-20	dB
63	125	250	500	1000	2000	4000	8000	Hz
1	3	-3	-4	-4	-7	-15	-19	dB

63	125	250	500	1000	2000	4000	8000	Hz
10	5	-1	-3	-5	-11	-16	-22	dB
63	125	250	500	1000	2000	4000	8000	Hz
5	7	0	-4	-6	-9	-14	-20	dB

RLM ..-1214

Technical Data

	Nominal motor power	Poles	Motor size	Motor voltage	Nominal frequency	Connection	Nominal motor current	Nominal motor speed	Max. fan speed	Max. operating frequency	Weight
RLM 55-	kW	-		V	Hz		A	1/min	1/min	Hz	kg
1214-8D-39	30.00	8	250 M	400	50	Δ	58.00	730	780	53	947
1214-8D-41	37.00	8	280 S	400	50	Δ	72.00	735	830	56	1065
1214-8D-42	45.00	8	280 M	400	50	Δ	87.00	735	890	60	1115

Technical Data

	Nominal motor power	Poles	Motor size	Motor voltage	Nominal frequency	Connection	Nominal motor current	Nominal motor speed	Max. fan speed	Max. operating frequency	Weight
RLM 55-Ex II 2G c IIB T4	kW	-		V	Hz		A	1/min	1/min	Hz	kg
1214-8Y-39-2G	30.00	8	250 M	400	50	Δ	58.00	730	770	52	1027
1214-8Y-41-2G	37.00	8	280 S	400	50	Δ	70.00	732	825	56	1160

Dimensions in mm, subject to change.

RLM 56-1214

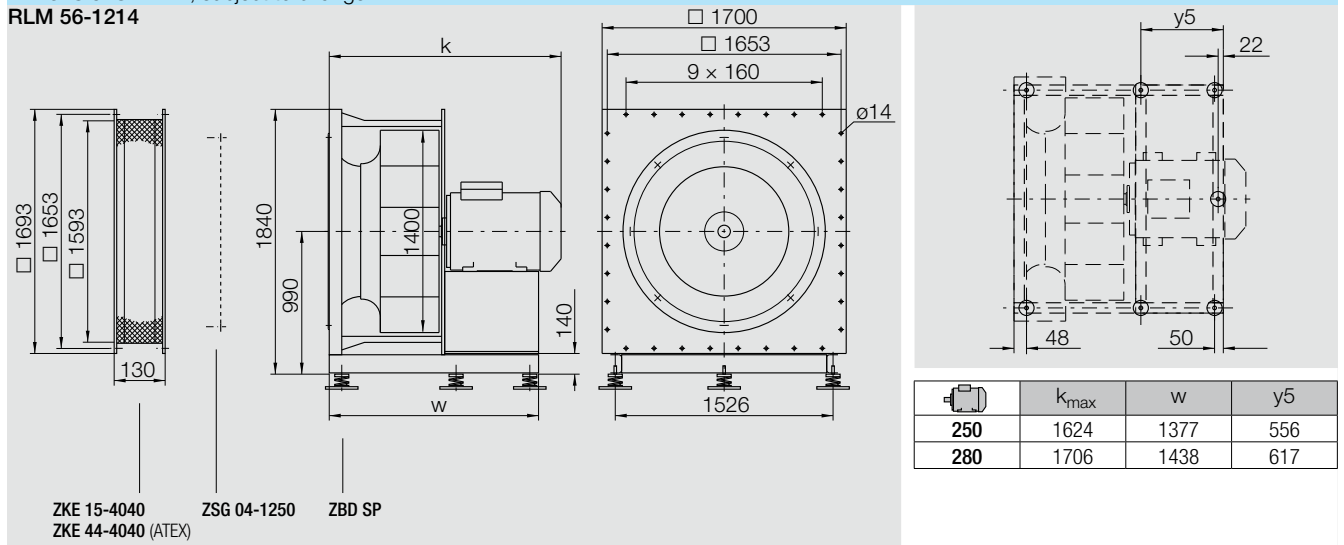

Accessories

	Frequency Inverter 6SE6430-	Control Panel for Frequency Inverter 6SE6420- and 6SE6430-	Line Choke for 3~
RLM 55-			
1214-8D-39	6SE6430-2AD33-0DA0	6SE6400-0BE00-0AA0	6SE6400-3CC05-2DD0
1214-8D-41	6SE6430-2AD33-7EA0	6SE6400-0BE00-0AA0	6SE6400-3CC08-3ED0
1214-8D-42	6SE6430-2AD34-5EA0	6SE6400-0BE00-0AA0	6SE6400-3CC08-3ED0
RLM 55-Ex II 2G c IIB T4			
1214-8Y-39-2G	6SE6430-2AD33-0DA0	6SE6400-0BE00-0AA0	6SE6400-3CC05-2DD0
1214-8Y-41-2G	6SE6430-2AD33-7EA0	6SE6400-0BE00-0AA0	6SE6400-3CC08-3ED0

Technical Data

Technical Data according to ErP-REGULATION 327/2011/EU

RLM 56-	Overall efficiency η_e [%]	Measure-ment category	Efficiency category	achieved ef- ficiency grade at optimum energy efficiency	required ef- ficiency grade acc. to ErP since		Speed control (VSD)	Rated motor power at optimum energy efficiency P_e [kW]	Flow rate at op- timum energy efficiency q_v [m³/h]	Pressure at op- timum energy efficiency p_F [Pa]	Speed at op- timum energy efficiency N [1/min]	"specific ratio"
				"N"	2013	2015						
2528-2D-08	48.2	A	STATIC	59.9	58	62	must be installed	0.76	2055	644	2980	1.006
2528-2W-10	52.5	A	STATIC	63.3	58	62	must be installed	0.93	2262	780	3280	1.008
2528-2W-11	54.0	A	STATIC	63.3	58	62	must be installed	1.30	2552	992	3700	1.010
2528-2W-13	55.2	A	STATIC	63.1	58	62	must be installed	1.73	2827	1218	4100	1.012
2528-2W-14	56.4	A	STATIC	62.8	58	62	must be installed	2.47	3207	1567	4650	1.016
2528-2W-16	57.4	A	STATIC	62.7	58	62	must be installed	3.11	3483	1848	5050	1.018
2831-2W-11	56.1	A	STATIC	65.3	58	62	must be installed	1.33	3033	886	3040	1.009
2831-2W-13	57.3	A	STATIC	65.1	58	62	must be installed	1.79	3372	1095	3380	1.011
2831-2W-14	58.6	A	STATIC	64.8	58	62	must be installed	2.55	3821	1406	3830	1.014
2831-2W-16	59.6	A	STATIC	64.6	58	62	must be installed	3.30	4191	1691	4200	1.017
2831-2W-19	60.4	A	STATIC	64.3	58	62	must be installed	4.28	4590	2029	4600	1.020
3135-2W-14	58.3	A	STATIC	64.5	58	62	must be installed	2.56	4573	1174	3150	1.012
3135-2W-16	59.3	A	STATIC	64.2	58	62	must be installed	3.42	5066	1441	3490	1.014
3135-2W-19	60.1	A	STATIC	63.8	58	62	must be installed	4.49	5574	1745	3840	1.017
3540-2W-16	59.6	A	STATIC	64.4	58	62	must be installed	3.47	5870	1267	2890	1.013
3540-2W-19	60.4	A	STATIC	64.2	58	62	must be installed	4.39	6378	1496	3140	1.015
3540-2W-21	61.3	A	STATIC	63.6	58	62	must be installed	6.04	7129	1869	3510	1.019
4045-2W-21	61.3	A	STATIC	63.4	58	62	must be installed	6.21	8376	1634	2930	1.016
4045-2W-22	62.0	A	STATIC	63.0	58	62	must be installed	8.06	9177	1962	3210	1.020
4550-2W-26	62.9	A	STATIC	62.9	58	62	must be installed	10.99	11722	2124	2955	1.021
2831-4D-10	47.2	A	STATIC	58.9	58	62	must be installed	0.76	2375	543	2380	1.005
2831-4W-11	56.1	A	STATIC	66.9	58	62	must be installed	0.93	2694	699	2700	1.007
3135-4W-11	55.8	A	STATIC	66.6	58	62	must be installed	0.94	3223	583	2220	1.006
3135-4W-13	57.0	A	STATIC	66.3	58	62	must be installed	1.31	3629	740	2500	1.007
3135-4W-14	58.0	A	STATIC	65.8	58	62	must be installed	1.81	4065	928	2800	1.009
3540-4W-11	56.1	A	STATIC	66.9	58	62	must be installed	0.92	3697	503	1820	1.005
3540-4W-13	57.3	A	STATIC	66.5	58	62	must be installed	1.32	4204	650	2070	1.007
3540-4W-14	58.3	A	STATIC	66.2	58	62	must be installed	1.79	4671	803	2300	1.008
3540-4W-16	59.4	A	STATIC	65.6	58	62	must be installed	2.53	5281	1026	2600	1.010
4045-4W-13	57.3	A	STATIC	66.5	58	62	must be installed	1.34	4917	563	1720	1.006
4045-4W-14	58.3	A	STATIC	66.1	58	62	must be installed	1.81	5460	695	1910	1.007
4045-4W-16	59.3	A	STATIC	65.4	58	62	must be installed	2.64	6232	905	2180	1.009
4045-4W-17	60.2	A	STATIC	65.0	58	62	must be installed	3.52	6890	1106	2410	1.011
4045-4W-19	61.0	A	STATIC	64.5	58	62	must be installed	4.61	7576	1337	2650	1.013
4550-4W-14	58.3	A	STATIC	66.2	58	62	must be installed	1.75	6188	592	1560	1.006
4550-4W-16	59.3	A	STATIC	65.6	58	62	must be installed	2.55	7061	771	1780	1.008
4550-4W-17	60.2	A	STATIC	64.9	58	62	must be installed	3.51	7894	963	1990	1.010
4550-4W-19	60.9	A	STATIC	64.5	58	62	must be installed	4.56	8648	1156	2180	1.012
4550-4W-21	61.7	A	STATIC	63.9	58	62	must be installed	6.23	9640	1436	2430	1.014
4550-4W-23	62.4	A	STATIC	63.5	58	62	must be installed	7.81	10433	1682	2630	1.017
5056-4W-16	59.3	A	STATIC	65.5	58	62	must be installed	2.56	8343	656	1470	1.007
5056-4W-17	60.2	A	STATIC	65.1	58	62	must be installed	3.38	9194	797	1620	1.008
5056-4W-19	61.0	A	STATIC	64.7	58	62	must be installed	4.43	10102	962	1780	1.010
5056-4W-21	61.7	A	STATIC	64.0	58	62	must be installed	6.11	11294	1202	1990	1.012
5056-4W-23	62.4	A	STATIC	63.3	58	62	must be installed	8.28	12542	1483	2210	1.015
5056-4W-26	63.2	A	STATIC	63.2	58	62	must be installed	11.14	13904	1823	2450	1.018
5663-4W-19	60.3	A	STATIC	63.9	58	62	must be installed	4.51	11899	823	1460	1.008
5663-4W-21	61.1	A	STATIC	63.4	58	62	must be installed	5.97	13121	1001	1610	1.010
5663-4W-23	61.8	A	STATIC	62.7	58	62	must be installed	8.11	14588	1237	1790	1.012
5663-4W-26	62.5	A	STATIC	61.8	58	62	must be installed	11.69	16544	1591	2030	1.016
5663-4W-28	63.1	A	STATIC	62.7	58	62	must be installed	15.78	18337	1954	2250	1.020
6371-4W-23	61.9	A	STATIC	63.0	58	62	must be installed	7.84	16626	1050	1480	1.011
6371-4W-26	62.7	A	STATIC	62.6	58	62	must be installed	11.53	18985	1369	1690	1.014
6371-4W-28	63.2	A	STATIC	62.8	58	62	must be installed	15.73	21119	1695	1880	1.017
6371-4W-30	63.6	A	STATIC	63.0	58	62	must be installed	19.38	22692	1956	2020	1.020
7180-4W-28	63.8	A	STATIC	63.3	58	62	must be installed	15.54	25092	1422	1530	1.014
7180-4W-30	64.2	A	STATIC	63.5	58	62	must be installed	19.02	26896	1634	1640	1.016
7180-4W-31	64.5	A	STATIC	63.6	58	62	must be installed	22.61	28536	1839	1740	1.018

Technical Data

Technical Data according to ErP-REGULATION 327/2011/EU

RLM 56-	Overall efficiency η_e [%]	Measure-ment category	Efficiency category	achieved ef-ficiency grade at optimum energy efficiency "N"	required ef-ficiency grade acc. to ErP since		Speed control (VSD)	Rated motor power at optimum energy efficiency P_e [kW]	Flow rate at op-timum energy efficiency q_v [m³/h]	Pressure at op-timum energy efficiency p_F [Pa]	Speed at op-timum energy efficiency N [1/min]	"specific ratio"
					2013	2015						
8090-4W-31	64.4	A	STATIC	63.6	58	62	must be installed	23.28	33277	1623	1465	1.016
8090-4W-34	64.9	A	STATIC	63.8	58	62	must be installed	30.66	36571	1960	1610	1.020
9010-4W-36	64.7	A	STATIC	63.2	58	62	must be installed	40.40	46889	2008	1480	1.020
5056-6W-16	56.2	A	STATIC	63.9	58	62	must be installed	1.83	7321	505	1290	1.005
5663-6W-19	57.0	A	STATIC	63.0	58	62	must be installed	2.65	9780	556	1200	1.006
5663-6W-21	58.0	A	STATIC	62.6	58	62	must be installed	3.62	10921	693	1340	1.007
6371-6W-21	58.1	A	STATIC	63.0	58	62	must be installed	3.43	12357	580	1100	1.006
6371-6W-23	59.0	A	STATIC	62.7	58	62	must be installed	4.49	13593	702	1210	1.007
6371-6W-24	60.0	A	STATIC	62.2	58	62	must be installed	6.13	15165	874	1350	1.009
7180-6W-23	59.5	A	STATIC	63.2	58	62	must be installed	4.51	16236	595	990	1.006
7180-6W-24	60.5	A	STATIC	62.7	58	62	must be installed	6.25	18204	748	1110	1.007
7180-6W-26	61.4	A	STATIC	62.3	58	62	must be installed	8.19	20008	904	1220	1.009
7180-6W-28	62.4	A	STATIC	62.3	58	62	must be installed	12.16	22960	1191	1400	1.012
8090-6W-26	61.3	A	STATIC	62.4	58	62	must be installed	8.01	22942	771	1010	1.008
8090-6W-28	62.4	A	STATIC	62.3	58	62	must be installed	11.63	26122	1000	1150	1.010
8090-6W-31	63.1	A	STATIC	62.7	58	62	must be installed	15.85	29075	1239	1280	1.012
8090-6W-33	63.6	A	STATIC	62.9	58	62	must be installed	19.71	31346	1440	1380	1.014
9010-6W-28	61.9	A	STATIC	61.8	58	62	must be installed	12.07	30889	871	975	1.009
9010-6W-31	62.6	A	STATIC	62.2	58	62	must be installed	16.23	34216	1069	1080	1.011
9010-6W-33	63.1	A	STATIC	62.4	58	62	must be installed	19.95	36750	1233	1160	1.012
9010-6W-34	63.5	A	STATIC	62.6	58	62	must be installed	23.65	38968	1387	1230	1.014
9010-6W-37	64.0	A	STATIC	62.8	58	62	must be installed	32.40	43404	1720	1370	1.017
1011-6W-34	63.5	A	STATIC	62.6	58	62	must be installed	22.40	44510	1150	1000	1.011
1011-6W-37	64.0	A	STATIC	62.8	58	62	must be installed	31.19	49851	1442	1120	1.014
1011-6W-39	64.4	A	STATIC	63.0	58	62	must be installed	38.16	53412	1656	1200	1.017
1011-6W-41	64.7	A	STATIC	63.1	58	62	must be installed	46.06	56973	1884	1280	1.019
1112-6W-39	64.4	A	STATIC	63.0	58	62	must be installed	38.24	61878	1432	1000	1.014
1112-6W-41	64.7	A	STATIC	63.2	58	62	must be installed	44.03	64972	1579	1050	1.016
8090-8W-26	60.6	A	STATIC	64.4	58	62	must be installed	4.34	18626	508	820	1.005
8090-8W-27	61.0	A	STATIC	63.3	58	62	must be installed	6.09	20898	640	920	1.006
9010-8W-27	60.5	A	STATIC	62.8	58	62	must be installed	6.08	24395	543	770	1.005
9010-8W-28	60.7	A	STATIC	61.4	58	62	must be installed	8.46	27246	678	860	1.007
1011-8W-31	61.4	A	STATIC	61.2	58	62	must be installed	11.86	35608	736	800	1.007
1011-8W-33	62.1	A	STATIC	61.7	58	62	must be installed	16.13	39614	911	890	1.009
1011-8W-36	62.7	A	STATIC	62.0	58	62	must be installed	19.44	42285	1038	950	1.010

RLM 55-	η_e [%]			"N"	2013	2015		P_e [kW]	q_v [m³/h]	p_F [Pa]	N [1/min]	
1112-8W-33	62.1	A	STATIC	61.7	58	62	must be installed	16.05	45790	784	740	1.008
1112-8W-36	62.7	A	STATIC	62.0	58	62	must be installed	19.36	48883	894	790	1.009
1112-8W-37	63.0	A	STATIC	62.2	58	62	must be installed	23.14	51977	1010	840	1.010
1112-8W-39	63.7	A	STATIC	62.5	58	62	must be installed	31.10	57546	1239	930	1.012
1214-8W-39	63.7	A	STATIC	62.5	58	62	must be installed	31.10	66939	1065	770	1.011
1214-8W-41	64.1	A	STATIC	62.7	58	62	must be installed	38.70	72155	1238	830	1.012
1214-8W-42	64.4	A	STATIC	62.8	58	62	must be installed	45.88	76502	1391	880	1.014
8090-8D-26	55.1	A	STATIC	58.3	58	62	must be installed	4.95	18853	521	830	1.005
8090-8D-27	57.6	A	STATIC	59.5	58	62	must be installed	6.66	21125	654	930	1.007
9010-8D-27	57.2	A	STATIC	59.0	58	62	must be installed	6.69	24712	558	780	1.006
9010-8D-28	58.6	A	STATIC	59.2	58	62	must be installed	8.76	27246	678	860	1.007
1011-8D-31	59.8	A	STATIC	59.6	58	62	must be installed	12.64	36053	754	810	1.008
1011-8D-33	60.7	A	STATIC	60.2	58	62	must be installed	17.06	40059	931	900	1.009
1011-8D-36	61.4	A	STATIC	60.7	58	62	must be installed	20.47	42730	1060	960	1.011
1112-8D-33	60.7	A	STATIC	60.2	58	62	must be installed	17.10	46408	806	750	1.008
1112-8D-36	61.4	A	STATIC	60.7	58	62	must be installed	20.51	49502	917	800	1.009
1112-8D-37	61.9	A	STATIC	60.9	58	62	must be installed	24.44	52596	1035	850	1.010
1112-8D-39	62.6	A	STATIC	61.4	58	62	must be installed	32.65	58165	1265	940	1.013
1214-8D-39	62.6	A	STATIC	61.4	58	62	must be installed	32.87	67808	1093	780	1.011
1214-8D-41	63.1	A	STATIC	61.7	58	62	must be installed	39.30	72155	1238	830	1.012
1214-8D-42	63.5	A	STATIC	61.9	58	62	must be installed	48.14	77371	1423	890	1.014

RLM 56-2528/-1011

Specifications

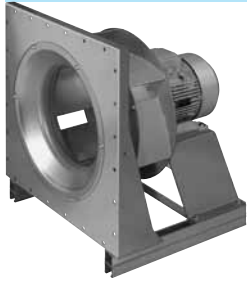

High performance centrifugal fan RLM

optimised for use without scroll, with motor incl. three PTC resistors, suitable for operation at frequency converter. Can only be used horizontally.
 Motor impeller with inlet cone, supporting plate, motor base and basic frame manufactured as a module and adjusted.
 Centrifugal impeller with backward curved blades of sheet steel, welded and coated, fastened on the shaft of the flange motor, balanced statically and dynamically according to DIN ISO 1940.
 Power data in precision class 1 according to DIN 24166.
 Equipped on inlet side with connection possibility for quadratic supports, with elastic spacer piece.
 Equipped with flow measuring device IMV as standard.

Variants (at choice)

Ex II 2G c IIB T4

- As a standard feature, with inlet cones made of copper
- safety guard on the inlet
- flame proof enclosure motor

Fan data

Fan type		
Volume flow	Q_V		m ³ /h
Static pressure	p_{sF}		Pa
Air density at fan inlet	ρ_1		kg/m ³
Air temperature	t		°C
Absorbed fan power	P_a		kW
Efficiency	f		Hz
Speed	N		1/min
Max. fan speed	N_{max}		1/min
Frequency	f		Hz
Max. operating frequency	f_{max}		Hz
Sound power level (A weighted)	L_{WA}		dB
Weight	m		kg

Fittings / Accessories

- Connection flange
- Discharge flange (with flexible sleeve)
- Inlet guards
- Anti-vibration mounts
- Frequency inverter (Unit with RFI filter Class B and control unit)
- Line reactor
- Universal control device
- Differential pressure sensor

RLM 55-1112/-1214

Specifications



High performance centrifugal fan RLM

optimised for use without scroll, with flange motor incl. three PTC resistors, suitable for operation at frequency converter. Can only be used horizontally. Motor impeller with inlet cone, bearing unit, motor base and basic frame manufactured as a module and adjusted.

Centrifugal impeller with backward curved blades of sheet steel, welded and coated, fastened on the shaft of the flange motor, balanced statically and dynamically according to DIN ISO 1940.

Power data in precision class 1 according to DIN 24166.

Equipped on inlet side with connection possibility for quadratic supports, with elastic spacer piece.

Equipped with flow measuring device IMV as standard.

Variants (at choice)

Ex II 2G c IIB T4

- As a standard feature, with inlet cones made of copper
- safety guard on the inlet
- flame proof enclosure motor

Fan data

Fan type		
Volume flow	Q_v		m ³ /h
Static pressure	p_{sF}		Pa
Air density at fan inlet	ρ_1		kg/m ³
Air temperature	t		°C
Absorbed fan power	P_a		kW
Efficiency	f		Hz
Speed	N		1/min
Max. fan speed	N_{max}		1/min
Frequency	f		Hz
Max. operating frequency	f_{max}		Hz
Sound power level (A weighted)	L_{WA}		dB
Weight	m		kg

Fittings / Accessories

- Connection flange
- Discharge flange (with flexible sleeve)
- Inlet guards
- Anti-vibration mounts
- Frequency inverter (Unit with RFI filter Class B and control unit)
- Line reactor
- Universal control device
- Differential pressure sensor

Fittings / Accessories

Accessories

All options and accessories must be specified separately. Please take the technical data and dimensions from the corresponding page of the catalogue.

Flanges and Flexible Connections



Flanges and nozzles with elastic spacer piece are available for the inlet side. The dimensions must be taken from the fan dimension diagram.

Inlet guard



The fans are designed for installation in equipment and as standard are not equipped with protective guards.

They should not be put into operation before all protective devices are fitted and connected!

Protective measures must be carried out as set out in DIN EN ISO 12100 "Safety of machinery - Basic concepts, general principles for design".

If the application of the fan allows free access to the inlet and discharge apertures, safety devices must be put in place on the fan in accordance with DIN EN ISO 13857! Suitable safety guards are available as an optional extra.

Anti Vibration Spring Diffusers

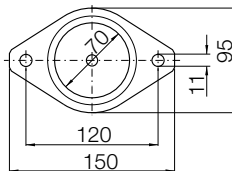
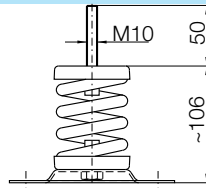

Anti Vibration Mounts (AVM) are designed to prevent noise and vibrations being transmitted through the base of the fan.

AVMs should be mounted beneath the fan base frame so the weight and spring deflections are evenly distributed. They should not be mounted symmetrically around the centre of gravity of the system when idle, because a counter force is induced into the system by the pressure created by the working fan.

It is difficult for the manufacturer to establish the position of the AVMs to suit all types of application.

Vibration and noise insulation can also be improved by ensuring that the fan is connected to its external environment by a flexible coupling. The AVMs are supplied with the suitable mounting material for the base frame (CC- or U-Profiles).

Fittings / Accessories

Anti Vibration Spring Diffusers

Quantity „z“ anti-vibration-mounts ZBD

Inlet-side ① / Motor-Side ②.

RLM 56-	z × ZBD ①	z × ZBD ②
2528-2D-16	2 × SP-7502	2 × SP-7502
2528-2D-14	2 × SP-7501	2 × SP-7501
2528-2D-13	2 × SP-7501	2 × SP-7501
2528-2D-11	2 × SP-7501	2 × SP-7501
2528-2D-10	2 × SP-7501	2 × SP-7501
2528-2D-08	2 × SP-7501	2 × SP-7501

RLM 56-	z × ZBD ①	z × ZBD ②
2831-2D-19	2 × SP-7502	2 × SP-7502
2831-2D-16	2 × SP-7502	2 × SP-7502
2831-2D-14	2 × SP-7501	2 × SP-7501
2831-2D-13	2 × SP-7501	2 × SP-7501
2831-2D-11	2 × SP-7501	2 × SP-7501
2831-4D-10	2 × SP-7501	2 × SP-7501

RLM 56-	z × ZBD ①	z × ZBD ②
3135-2D-19	2 × SP-7502	2 × SP-7502
3135-2D-16	2 × SP-7502	2 × SP-7502
3135-2D-14	2 × SP-7501	2 × SP-7501
3135-4D-13	2 × SP-7501	2 × SP-7501
3135-4D-11	2 × SP-7501	2 × SP-7501

RLM 56-	z × ZBD ①	z × ZBD ②
3540-2D-21	2 × SP-7502	2 × SP-7502
3540-2D-19	2 × SP-7502	2 × SP-7502
3540-2D-16	2 × SP-7502	2 × SP-7502
3540-4D-16	2 × SP-7502	2 × SP-7502
3540-4D-14	2 × SP-7501	2 × SP-7501
3540-4D-13	2 × SP-7501	2 × SP-7501
3540-4D-11	2 × SP-7501	2 × SP-7501

RLM 56-	z × ZBD ①	z × ZBD ②
4045-2D-22	2 × SP-7502	2 × SP-7503
4045-2D-21	2 × SP-7502	2 × SP-7503
4045-4D-17	2 × SP-7502	2 × SP-7502
4045-4D-16	2 × SP-7502	2 × SP-7502
4045-4D-14	2 × SP-7502	2 × SP-7502
4045-4D-13	2 × SP-7502	2 × SP-7502

RLM 56-	z × ZBD ①	z × ZBD ②
4550-2D-26	2 × SP-7502	2 × SP-7503
4550-4D-23	2 × SP-7502	2 × SP-7503
4550-4D-21	2 × SP-7502	2 × SP-7503
4550-4D-19	2 × SP-7502	2 × SP-7502
4550-4D-17	2 × SP-7502	2 × SP-7502
4550-4D-16	2 × SP-7502	2 × SP-7502
4550-4D-14	2 × SP-7502	2 × SP-7502

RLM 56-	z × ZBD ①	z × ZBD ②
5056-4D-26	2 × SP-7502	2 × SP-7503
5056-4D-23	2 × SP-7502	2 × SP-7503
5056-4D-21	2 × SP-7502	2 × SP-7503
5056-4D-19	2 × SP-7502	2 × SP-7503
5056-4D-17	2 × SP-7502	2 × SP-7502
5056-4D-16	2 × SP-7502	2 × SP-7502
5056-6D-16	2 × SP-7502	2 × SP-7502

Quantity „z“ anti-vibration-mounts ZBD

Inlet-side ① / Motor-Side ②.

RLM 56-	z × ZBD ①	z × ZBD ②
5663-4D-28	2 × SP-7503	2 × SP-7504
5663-4D-26	2 × SP-7502	2 × SP-7503
5663-4D-23	2 × SP-7502	2 × SP-7503
5663-4D-21	2 × SP-7502	2 × SP-7503
5663-4D-19	2 × SP-7502	2 × SP-7503
5663-6D-21	2 × SP-7502	2 × SP-7503
5663-6D-19	2 × SP-7502	2 × SP-7503

RLM 56-	z × ZBD ①	z × ZBD ②
6371-4D-30	2 × SP-7503	2 × SP-7504
6371-4D-28	2 × SP-7503	2 × SP-7504
6371-4D-26	2 × SP-7503	2 × SP-7504
6371-4D-23	2 × SP-7502	2 × SP-7503
6371-6D-24	2 × SP-7502	2 × SP-7503
6371-6D-23	2 × SP-7502	2 × SP-7503
6371-6D-21	2 × SP-7502	2 × SP-7503

RLM 56-	z × ZBD ①	z × ZBD ②
7180-4D-31	2 × SP-7504	3 × SP-7504
7180-4D-30	2 × SP-7504	3 × SP-7504
7180-4D-28	2 × SP-7503	3 × SP-7503
7180-6D-28	2 × SP-7503	3 × SP-7503
7180-6D-26	2 × SP-7503	3 × SP-7503
7180-6D-24	2 × SP-7503	3 × SP-7503
7180-6D-23	2 × SP-7503	3 × SP-7503

RLM 56-	z × ZBD ①	z × ZBD ②
8090-4D-34	2 × SP-7505	3 × SP-7505
8090-4D-31	2 × SP-7504	3 × SP-7504
8090-6D-33	2 × SP-7505	3 × SP-7505
8090-6D-31	2 × SP-7504	3 × SP-7504
8090-6D-28	2 × SP-7504	3 × SP-7504
8090-6D-26	2 × SP-7503	3 × SP-7503
8090-8D-27	2 × SP-7503	3 × SP-7503
8090-8D-26	2 × SP-7503	3 × SP-7503

RLM 56-	z × ZBD ①	z × ZBD ②
9010-4D-36	2 × SP-7505	3 × SP-7505
9010-6D-37	2 × SP-7505	3 × SP-7505
9010-6D-34	2 × SP-7505	3 × SP-7505
9010-6D-33	2 × SP-7505	3 × SP-7505
9010-6D-31	2 × SP-7504	3 × SP-7504
9010-6D-28	2 × SP-7504	3 × SP-7504
9010-8D-28	2 × SP-7504	3 × SP-7504
9010-8D-27	2 × SP-7504	3 × SP-7504

RLM 56-	z × ZBD ①	z × ZBD ②
1011-6D-41	2 × SP-7506	5 × SP-7506
1011-6D-39	2 × SP-7506	5 × SP-7506
1011-6D-37	2 × SP-7505	5 × SP-7505
1011-6D-34	2 × SP-7505	4 × SP-7505
1011-8D-36	2 × SP-7505	5 × SP-7505
1011-8D-33	2 × SP-7505	4 × SP-7505
1011-8D-31	2 × SP-7505	4 × SP-7505

RLM 55-	z × ZBD
1112-6D-41	7 × SP-7506
1112-6D-39	7 × SP-7506
1112-8D-39	7 × SP-7506
1112-8D-37	7 × SP-7506
1112-8D-36	7 × SP-7506
1112-8D-33	6 × SP-7505

RLM 55-	z × ZBD
1214-8D-42	7 × SP-7506
1214-8D-41	7 × SP-7506
1214-8D-39	7 × SP-7506

Fittings / Accessories

Anti Vibration Spring Diffusers

Quantity „z“ anti-vibration-mounts ZBD for the inlet-side ① and the motor-Side ②.

RLM 56-	z × ZBD ①	z × ZBD ②
2528-2Y-16-2G	2 × SP-7502	2 × SP-7503
2528-2Y-15-2G	2 × SP-7501	2 × SP-7502
2528-2Y-14-2G	2 × SP-7501	2 × SP-7502
2528-2Y-11-2G	2 × SP-7501	2 × SP-7502
2528-2Y-10-2G	2 × SP-7501	2 × SP-7502
2528-2Y-08-2G	2 × SP-7501	2 × SP-7502

RLM 56-	z × ZBD ①	z × ZBD ②
2831-2Y-19-2G	2 × SP-7502	2 × SP-7503
2831-2Y-16-2G	2 × SP-7502	2 × SP-7503
2831-2Y-15-2G	2 × SP-7501	2 × SP-7502
2831-2Y-14-2G	2 × SP-7501	2 × SP-7502
2831-2Y-11-2G	2 × SP-7501	2 × SP-7502
2831-4Y-10-2G	2 × SP-7501	2 × SP-7502

RLM 56-	z × ZBD ①	z × ZBD ②
3135-2Y-19-2G	2 × SP-7502	2 × SP-7503
3135-2Y-16-2G	2 × SP-7502	2 × SP-7503
3135-2Y-15-2G	2 × SP-7501	2 × SP-7502
3135-4Y-14-2G	2 × SP-7501	2 × SP-7502
3135-4Y-11-2G	2 × SP-7501	2 × SP-7502

RLM 56-	z × ZBD ①	z × ZBD ②
3540-2Y-21-2G	2 × SP-7502	2 × SP-7503
3540-2Y-19-2G	2 × SP-7502	2 × SP-7503
3540-2Y-16-2G	2 × SP-7502	2 × SP-7503
3540-4Y-16-2G	2 × SP-7502	2 × SP-7503
3540-4Y-15-2G	2 × SP-7501	2 × SP-7502
3540-4Y-14-2G	2 × SP-7501	2 × SP-7502
3540-4Y-11-2G	2 × SP-7501	2 × SP-7502

RLM 56-	z × ZBD ①	z × ZBD ②
4045-2Y-22-2G	2 × SP-7502	2 × SP-7503
4045-2Y-21-2G	2 × SP-7502	2 × SP-7503
4045-4Y-17-2G	2 × SP-7502	2 × SP-7503
4045-4Y-16-2G	2 × SP-7502	2 × SP-7503
4045-4Y-15-2G	2 × SP-7502	2 × SP-7503
4045-4Y-14-2G	2 × SP-7502	2 × SP-7503

RLM 56-	z × ZBD ①	z × ZBD ②
4550-4Y-23-2G	2 × SP-7503	2 × SP-7504
4550-4Y-21-2G	2 × SP-7503	2 × SP-7504
4550-4Y-19-2G	2 × SP-7502	2 × SP-7503
4550-4Y-17-2G	2 × SP-7502	2 × SP-7503
4550-4Y-16-2G	2 × SP-7502	2 × SP-7503
4550-4Y-15-2G	2 × SP-7502	2 × SP-7502

RLM 56-	z × ZBD ①	z × ZBD ②
5056-4Y-26-2G	2 × SP-7503	2 × SP-7504
5056-4Y-23-2G	2 × SP-7503	2 × SP-7504
5056-4Y-21-2G	2 × SP-7503	2 × SP-7504
5056-4Y-19-2G	2 × SP-7502	2 × SP-7503
5056-4Y-17-2G	2 × SP-7503	2 × SP-7503
5056-4Y-16-2G	2 × SP-7502	2 × SP-7503
5056-6Y-16-2G	2 × SP-7503	2 × SP-7503

Quantity „z“ anti-vibration-mounts ZBD for the inlet-side ① and the motor-Side ②.

RLM 56-	z × ZBD ①	z × ZBD ②
5663-4Y-26-2G	2 × SP-7503	2 × SP-7504
5663-4Y-23-2G	2 × SP-7503	2 × SP-7504
5663-4Y-21-2G	2 × SP-7503	2 × SP-7504
5663-4Y-19-2G	2 × SP-7503	2 × SP-7504
5663-6Y-21-2G	2 × SP-7503	2 × SP-7504
5663-6Y-19-2G	2 × SP-7502	2 × SP-7503

RLM 56-	z × ZBD ①	z × ZBD ②
6371-4Y-28-2G	2 × SP-7504	2 × SP-7505
6371-4Y-26-2G	2 × SP-7504	2 × SP-7505
6371-4Y-23-2G	2 × SP-7503	2 × SP-7504
6371-6Y-24-2G	2 × SP-7503	2 × SP-7504
6371-6Y-23-2G	2 × SP-7503	2 × SP-7504
6371-6Y-21-2G	2 × SP-7503	2 × SP-7504

RLM 56-	z × ZBD ①	z × ZBD ②
7180-4Y-30-2G	2 × SP-7505	3 × SP-7505
7180-4Y-28-2G	2 × SP-7504	3 × SP-7505
7180-6Y-28-2G	2 × SP-7504	3 × SP-7504
7180-6Y-26-2G	2 × SP-7504	3 × SP-7504
7180-6Y-24-2G	2 × SP-7504	3 × SP-7504
7180-6Y-23-2G	2 × SP-7504	3 × SP-7504

RLM 56-	z × ZBD ①	z × ZBD ②
8090-4Y-34-2G	2 × SP-7505	3 × SP-7505
8090-4Y-31-2G	2 × SP-7504	3 × SP-7504
8090-6Y-33-2G	2 × SP-7505	3 × SP-7505
8090-6Y-31-2G	2 × SP-7505	3 × SP-7505
8090-6Y-28-2G	2 × SP-7505	3 × SP-7505
8090-6Y-26-2G	2 × SP-7504	3 × SP-7504
8090-8Y-27-2G	2 × SP-7504	3 × SP-7504
8090-8Y-26-2G	2 × SP-7504	3 × SP-7504

RLM 56-	z × ZBD ①	z × ZBD ②
9010-6Y-37-2G	2 × SP-7505	3 × SP-7505
9010-6Y-34-2G	2 × SP-7505	3 × SP-7505
9010-6Y-33-2G	2 × SP-7505	3 × SP-7505
9010-6Y-31-2G	2 × SP-7505	3 × SP-7505
9010-6Y-28-2G	2 × SP-7505	3 × SP-7505
9010-8Y-28-2G	2 × SP-7505	3 × SP-7505
9010-8Y-27-2G	2 × SP-7505	3 × SP-7505

RLM 56-	z × ZBD ①	z × ZBD ②
1011-6Y-41-2G	2 × SP-7506	5 × SP-7506
1011-6Y-39-2G	2 × SP-7506	5 × SP-7506
1011-6Y-37-2G	2 × SP-7505	5 × SP-7505
1011-6Y-34-2G	2 × SP-7505	4 × SP-7505
1011-8Y-36-2G	2 × SP-7505	5 × SP-7505
1011-8Y-34-2G	2 × SP-7505	4 × SP-7505
1011-8Y-31-2G	2 × SP-7505	4 × SP-7505

RLM 55-	z × ZBD
1112-8Y-39-2G	7 × SP-7506
1112-8Y-37-2G	7 × SP-7506
1112-8Y-36-2G	7 × SP-7506
1112-8Y-34-2G	6 × SP-7505

RLM 55-	z × ZBD
1214-8Y-41-2G	7 × SP-7506
1214-8Y-39-2G	7 × SP-7506

Fittings / Accessories

Volumeter

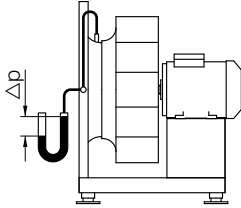

The fans are equipped with a flow measuring device as standard. With the flow measuring device it is possible to measure/monitor the flow easily after the fan is installed.

- pressure tapings in inlet cones (outside diameter 6mm)

For pressure measurement A pressure tapping at a predetermined position on the inlet cone is provided whereby the decrease in pressure created by the cone can be measured. The decrease in pressure measured can be inserted in the following formula.

$$q_v = K \times \sqrt{\frac{2}{\rho} \times \Delta p_{D\bar{u}}}$$

- **Volume flow q_v [m³/h]**
- **Calibration factor K [m²s/h]**
- **Density of media ρ [kg/m³]**
- **Pressure difference at cone $\Delta p_{D\bar{u}}$ [Pa]**

The K factor is determined by comparative measurement on a standard test ring.

Admissible maximum tolerance: Standard-calibration faktor K10 <10%

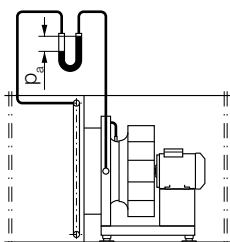

When fans are built in a plenum, it is required to measure the differential pressure between the static pressure in the plenum on the suction side and the pressure at the inlet cone.

To ensure that the static pressure to be measured at the inlet nozzle is not distorted by dynamic velocities, it is recommended to attach a ring of points on the wall as shown in the following diagram.

If the differential pressure is conducted via a pressure sensor, the signal can also be used for controlling.

Detailed description, measurement and connection diagram and calibration factors available on request.

Calibration factors

Size	Standard calibration factor K10 m²s/h
2528	73
2831	90
3135	105
3540	120
4045	150
4550	190
5056	240
5663	300
6371	385
7180	485
8090	620
9010	790
1011	1000
1112	1260
1214	1540

Accessories

Electrical accessories (Frequency converter, Differential pressure sensor, Universal control device, Isolator) see chapter "Accessories".

Description

Correction of design for installation in an enclosure

$$A = \sqrt{B \times H}$$

$$N_K = N \times f_N$$

$$P_{L,K} = P_L \times f_N^3$$

The installation of the fan in an enclosure leads to a reduction of pressure and flow compared to the stated performance characteristics. The following diagram shows the speed correction factor f_N as a function of the size of the enclosure when the box sections are quadratic and the fan is laid out symmetrically (inflow and outflow according to the diagram).

For enclosure sections with different sides lengths a quadratic equivalent parameter can be calculated from enclosure height H and enclosure width B as an approximation when there is a minimum distance of $0.3 \times D$ between the impeller and the casing wall.

When fans with flange motors are used in box casings, the speed and power stated in the performance map must be corrected with the factor from the diagram above according to the following equations:

The calculated speed must not exceed the admissible maximum speed of the fan.

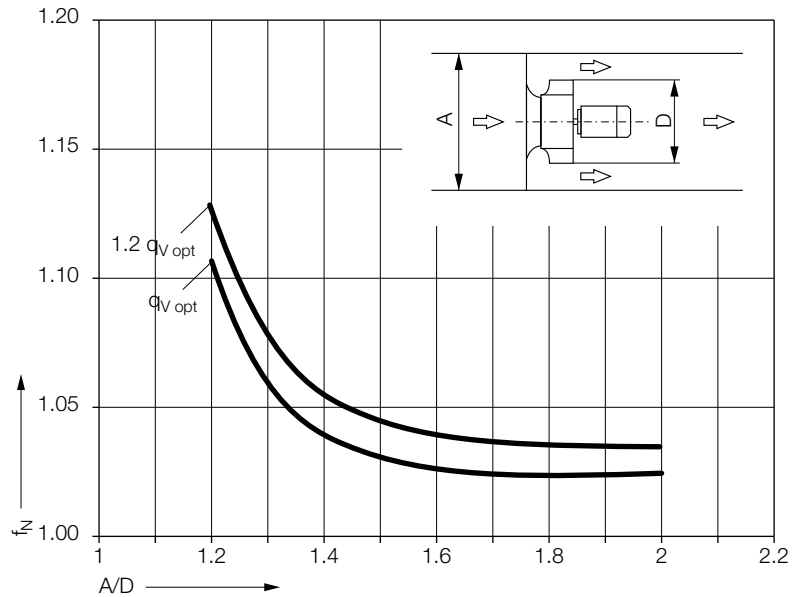

Symbols / Index

- A = Enclosure size
- B = Width of casing
- D = Impeller diameter
- f_N = Speed correction factor
- H = Height of casing
- K = Casing
- N = Fan speed
- P_L = Absorbed fan power

Description

Installation note

Minimum distances to walls and components.

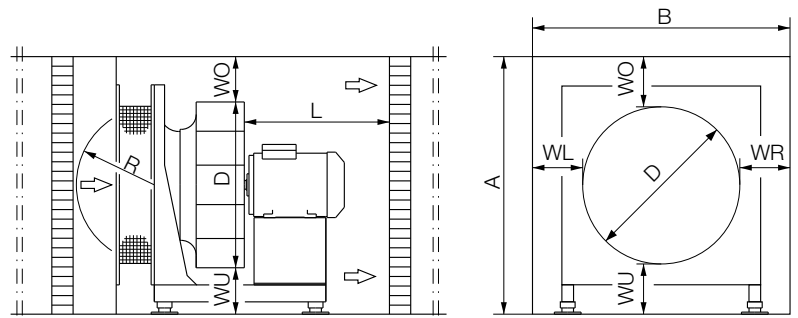

RLM	D	$\geq 0.5 \times D$	$\geq 1 \times D$	$\geq 0.3 \times D$	$\geq 0.2 \times D$	$\geq 0.3 \times D$	$\geq 0.3 \times D$	$\geq 1.6 \times D$	$\geq 1.6 \times D$
		R	L	WO	WU	WL	WR	A	B
56-2528	288	145	288	90	60	90	90	465	465
56-2831	323	165	323	100	65	100	100	520	520
56-3135	363	185	363	110	73	110	110	585	585
56-3540	406	205	406	125	82	125	125	650	650
56-4045	455	230	455	140	91	140	140	730	730
56-4550	510	255	510	155	105	155	155	820	820
56-5056	570	285	570	175	115	175	175	915	915
56-5663	640	320	640	195	130	195	195	1025	1025
56-6371	718	360	718	220	145	220	220	1150	1150
56-7180	808	405	808	245	165	245	245	1300	1300
56-8090	905	455	905	275	185	275	275	1450	1450
56-9010	995	500	995	300	200	300	300	1600	1600
56-1011	1120	560	1120	340	225	340	340	1800	1800
55-1112	1250	625	1250	375	250	375	375	2000	2000
55-1214	1400	700	1400	420	280	420	420	2240	2240

Description

Performance data



The performance curves of the fans are determined at the plenum test rig according to ISO 5801, measured in installation "A". The curves show a free discharge pressure rise p_{sF} as a function of the volume flow rate q_v in double logarithmic grid distribution. The resistant curves appear as straight lines.

The fan curves are related to a reference density of $\rho_1 = 1.2\text{kg/m}^3$ at the fan intake. The pressure and impeller power are directly proportional to the density ρ_1 .

The efficiencies given in the performance curves are only valid for the fan. Losses of motors and the control equipment are not included.

The performance data of the RLM centrifugal fans are classified in precision class 1 according to DIN 24166 "Fans, technical delivery conditions".

System efficiency

$$\eta_{se} = \eta_F \times \eta_M \times \eta_{sr}$$

$$P_e = \frac{q_v \times p_{sF}}{\eta_{se}}$$

The system efficiency is the product of the efficiencies of the frequency inverter, motor and impeller.

The electric power of the fan taken from the mains can be determined with the system efficiency.

Sounds

$$L_{WA5} = L_{WA8} - 4 \text{ dB}$$

Sound measurement and analysis are carried out in accordance with DIN 45635-38 "Sound measurement at machines; fans".

In the performance maps the A sound power level L_{WA8} is stated as emission parameter for the discharge side.

The value for the inlet side L_{WA5} can be calculated with the stated formula.

Soundproofing

The unweighted sound power levels in the octave band corrections are important for precise calculations in order to define sound protection measures.

They can be calculated with the following formulas and the values of the tables below the fan curves of each size.

- $L_{Wfc8} = L_{WA8} + L_{Wrel8}$
- $L_{Wfc5} = L_{WA5} + L_{Wrel5}$

Relative sound power level

$$f_{BP} = \frac{N \times z}{60}$$

The stated relative levels were averaged within a performance range of 0.8 up to 1.35 q_{Vopt} .

At operating points outside this range higher deviations from the stated values can be expected, in particular at low frequencies.

In isolated cases, the sound power levels at the octave bands can reach in the frequency range of the blade tone values somewhat higher than those calculated with the table.

Description

General

The fans in this catalogue are designed for installation in equipment. Due to their special shape, the impellers represent the ultimate in technology and economy achievable today.

The fan series is classified according to the standard line R20 and practically cover the suitable applications for fans without casing.

They are suitable for handling air and other non aggressive gases.

Temperatures

The permitted flow medium temperature is between -20°C and +40°C.

The maximum ambient temperature at the motor is +40°C.

Impeller

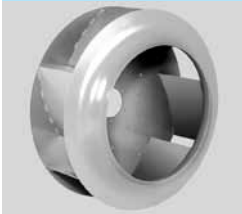

All impellers are balanced statically and dynamically according to DIN ISO 1940, specification G2.5, based on the maximum speed from size 4550.

The line 50 impellers with backward curved blades made of sheet steel, are welded and coated.

Direction of rotation

RLM centrifugal fans without casing are supplied with the direction of rotation RD (righthand turning) as standard.

The direction of rotation is determined by the viewing direction of the drive side.

Inlet Cones

The inlet cones are aerodynamically shaped for a good inflow to the impeller. In modularly designed fans the gap and overlap of the impeller is optimally adjusted and fixed permanently.

Motors

Standard motors of wellknown brands, type of protection IP55, thermal class F, are used. During commissioning and maintenance the detailed instructions provided by the motor manufacturer (type plate/motor operating instructions) must be followed, this also applies to the motor protection devices required onsite. The motors are equipped with PTC resistors/temperature sensors as standard. Motors with integrated frequency inverters may be supplied on request.

Speed variation

A suitable speed variation system is required for the optimum adjustment of the desired operating point.

The frequency inverters are perfectly tuned for the operation of RLM plug-fans with flange motors.

Electric connection

The centrifugal fans are delivered ready for installation.

The motor terminal box can be accessed easily.

Electric installation must be carried out according to the applicable provisions in compliance with local regulations. A terminal board circuit diagram showing correct connection is enclosed with every motor.

Updated circuit diagrams are also available online at www.nicotra-gebhardt.com.

In case of operation with frequency inverters, always follow the respective operating instructions!

Description

Explosion protection according to ATEX



Fans for operation in ex-hazardous areas have to conform to the EU Directive 94/9/EC (ATEX 95). Units of the group II (all applications except mining) are classified corresponding to their degree of safety into categories 1, 2 and 3. A further distinction is made according to their use in G (gas, vapour) or D (dust) environment. Harmonised European standards and national guidelines are to be observed.

The centrifugal fans RLM comply with the requirements of ATEX Directive 94/9/EG due to their structural safety and reliable construction in accordance with DIN EN 13463-1 and -5, pr EN 14986 : 2004. Allocation is to device group II, category 2G, explosion group IIB, temperature class T4.

ATEX category Ex II 2G c IIB T4

Fans in this category are designed to be used in areas where there is a risk of an explosive atmosphere consisting of a mixture of air and gases, vapours or mist existing occasionally. The device-related explosion prevention measures for this category must provide the required degree of safety even where there are frequent device malfunctions or error conditions which must be taken into account as a matter of course (foreseeable malfunctions). For the operation of fans in areas subject to a risk of explosion the relevant provisions and local regulations as well as corresponding directives (ATEX 95, 137) for both the manufacturer and operator must be observed.

Accessories

Frequency converter



Design

Frequency inverter with variable output voltage and frequency, specially designed for the operation of centrifugal fans with induction motors. Due to the use of modern power semiconductors it is possible to achieve a speed of revolution with high efficiency. Switching frequencies up to 16kHz can be set with all types. If the highest switching frequencies are required (for example for reasons of noise reduction), the maximum output current is decreased, in which case the performance category should be specially checked.

The overall package includes the frequency inverter, filter for class B (for residential and commercial uses) as well as a control unit.

General Performance characteristics

Motor protection feature for motors with thermistor temperature sensors, adjustable acceleration and deceleration ramps, minimum and maximum rotation speeds, fixed rotation speeds, trapping switch during operation, programmable inputs and PI-controller (MM420 and MM430 only), RS485 serial interface as well as a detailed operating instructions. Caution about combination with isolators (ESH)! Special EMC-action can be necessary, furthermore do not switch during operation, overvoltages can destroy the switch and the motor-winding.

Performance range G110 1AC 230V (for single-phase AC supply)

0.25kW to 2.2kW rated motor power, 200V to 240V 10% single-phase AC, 47Hz up to 63Hz, three-phase current output 3x230V AC, protection class IP20. Permitted ambient temperature during operation: -10°C up to +40°C.

Performance range MM420 3AC 400V (for three-phase AC supply)

0.55kW to 11kW rated motor power, 380V to 480V 10% three-phase AC, 47Hz up to 63Hz, three-phase current output 3x400V AC, protection class IP20. Permitted ambient temperature during operation: -10°C up to +50°C. The interference suppression filter required to comply with the EMC basic interference suppression standard EN 50081-1 (residential and commercial uses) is integrated into the package as substructure option. Power choke to comply with EN 61000-3-2 as additional component.

Observe performance reduction when using high clock frequencies!

Performance range MM430 3AC 400V

(for three-phase AC supply)

15kW to 250kW rated motor power, 380V to 480V 10% three-phase AC, 47Hz up to 63Hz, three-phase current output 3x400V AC, protection class IP20.

Permitted ambient temperature during operation: -10°C up to +50°C. The interference suppression filter required to comply with the EMC basic interference suppression standard EN 50081-1 (industrial applications) is partially integrated. In order to attain EMC requirements Class B a frequency inverter without filter should be selected. The appropriate EMC-B filter is then required as an additional component.

Observe performance reduction when using high clock frequencies!

The indicated ratings of the units are made for a quick selection. The exact dedication of an inverter in this catalogue is made by taking into account of the max. admitted current at a pulse frequency of 4kHz. It is important to know that at higher pulse frequencies the supplied current of the inverter will be decreasing, with the possible consequences of having to select a larger inverter unit. Also longer feed lines or additional radio frequency filters may lead to the choice of a larger inverter size.

The selected frequency inverters (G110 und MM420) are units contains the frequency inverter (as shown in the following tables) with the matching interference suppression filter (Class B) and a control panel. A further component is the line choke which is available as an accessorie. For more information the available frequency inverters are shown in the following tables.

Accessories

Frequency converter

Technical Data | Dimensions

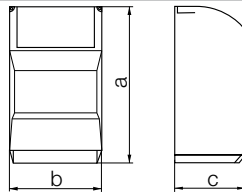

For three-phase AC motors on the single-phase supply.

6SL3211-	Nominal power kW	Nominal current A	a mm	b mm	c mm	Weight kg
0AB12-5BA0	0.25	1.7	150	90	116	0.8
0AB13-7BA0	0.37	2.3	150	90	116	0.8
0AB15-5BA0	0.55	3.2	150	90	131	0.9
0AB17-5BA0	0.75	3.9	150	90	131	0.9
0AB21-1AA0	1.1	6	160	140	142	1.5
0AB21-5AA0	1.5	7.8	160	140	142	1.5
0AB22-2AA0	2.2	11	181	184	152	2.1

Technical Data | Dimensions

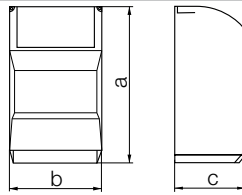

For three-phase AC motors on the three-phase supply

6SE6420-	Nominal power kW	Nominal current A	a mm	b mm	c mm	Weight kg
2UD15-5AA1	0.55	1.6	173	73	149	1
2UD17-5AA1	0.75	2.1	173	73	149	1
2UD21-1AA1	1.1	3	173	73	149	1
2UD21-5AA1	1.5	4	173	73	149	1
2AD22-2BA1	2.2	5.9	202	149	172	3.3
2AD23-0BA1	3	7.7	202	149	172	3.3
2AD24-0BA1	4	10.2	202	149	172	3.3
2AD25-5CA1	5.5	13.2	245	185	195	5
2AD27-5CA1	7.5	18.4	245	185	195	5
2AD31-1CA0	11	26	245	185	195	5

Technical Data | Dimensions

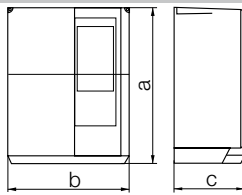

For three-phase AC motors on the three-phase supply

6SE6430-	Nominal power kW	Nominal current A	a mm	b mm	c mm	Weight kg
2AD31-5CA0	15	32	245	185	195	5.7
2AD31-8DA0	18.5	38	520	275	245	17
2AD32-2DA0	22	45	520	275	245	17
2AD33-0DA0	30	62	520	275	245	17
2AD33-7EA0	37	75	650	275	245	22
2AD34-5EA0	45	90	650	275	245	22
2AD35-5FA0	55	110	1150	350	320	75
2AD37-5FA0	75	145	1150	350	320	75
2AD37-8FA0	90	178	1150	350	320	75
2UD41-1FA0	110	180.4	1450	326	356	116
2UD41-3FA0	132	220	1450	326	356	116
2UD41-6GA0	160	265.8	1533	326	545	116
2UD42-0GA0	200	325.6	1533	326	545	116
2UD42-5GA0	250	419.8	1533	326	545	116

Motor protection unit



Motor protection unit EUM 33

Motor protection unit for three-phase current motors (standard motors) without thermal contacts.

Design

Plastic casing in protection class IP55, permissible ambient temperature +40°C, 40Hz up to 60Hz, frontal operation, for wall mounting. Motor protection unit for single-speed, non-variable speed three-phase current motors without thermal contacts.

Function

The motor protection units must be adjusted on site to the trigger current. If the preset trigger current is exceeded, the device disconnects the motor from the mains supply via a thermal overload release. Pressing the "on key" causes the unit to turn on again.

All motor protection units EUM33 are also suitable for the protection of EExe-motors (PTB-Prüfung Gesch-Nr. 3.35/386.3060). They must however be mounted outside of explosion endangered areas, since they are not themselves designed with explosion protection.

Technical Data

EUM 33-	Continuous current A	Setting range A	Max. nominal power kW
0004-8D	0.4	+0.2/+0.4	0.09
0006-8D	0.6	+0.4/+0.6	0.12
0010-8D	1	+0.6/+1	0.25
0016-8D	1.6	+1/+1.6	0.55
0024-8D	2.4	+1.6/+2.4	0.8
0040-8D	4	+2.4/+4	1.5
0060-8D	6	+4/+6	2.5
0100-8D	10	+6/+10	4
0160-8D	16	+10/+16	7.5
0200-8D	20	+16/+20	9
0250-8D	25	+20/+25	12.5
0500-8D	50	+25/+50	25
0580-8D	58	+50/+58	30

Dimensions in mm, subject to change.

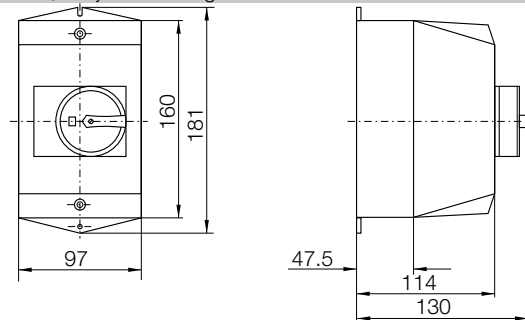

Wiring Diagram

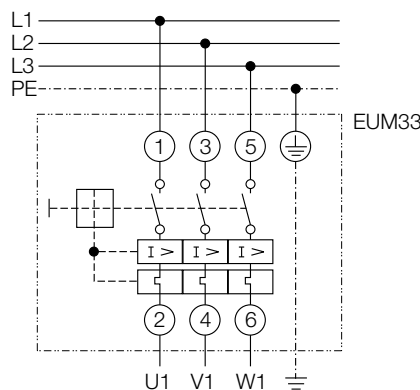

Accessories

Universal control device



Universal control device for installation in control cabinets Digital control module for controlling pressure, air velocity or volume flow (PI controller). For example, a transformer for fans is controlled via the 0...10V output. The device is designed for installation in control cabinets.

Type

Multi functional LC-display for actual and nominal values (m/s, hPa = mbar, 100m³/h). Menuassisted adjustment via three function keys.

Actual value input 0...10V e. g. for:

- air speed sensors Type EIL in measuring ranges from 0...1m/s and 0...10m/s e. g. for Air velocity control in clean room technology
- Pressure sensors Type EIP in measurement ranges 50Pa up to 4000Pa e. g. for Pressure control in canal systems of air conditioning systems (VVS) and Flow control in centrifugal fans with pressure tapplings in the inlet cone

The control module calculates the required flow (m³/h) from the differential measured pressure between the surrounding level and inlet cone.

- Output 0...10V e. g. for controlling a transformer
- Failure message is output via display (internal/external) and relay programmable
- External set value specification via potentiometer or 0...10V signal
- Specification of two set values (day/night), can be switched over externally or via keyboard
- Protection against unauthorised setting by keyboard code

Application area

- Pressure regulation for centralised ventilation systems and variable volume flow systems for building air conditioning (VVS) e.g. in combination with a frequency inverter or a commutation unit or a transformer and a pressure sensor
- Volume flow regulation for centrifugal fans (with measuring stub in the inlet cone) e.g. in combination with a frequency inverter or a commutation unit or a transformer or a mini-interface inverter and a pressure sensor and the volume flow volumeter
- Air speed regulation for clean room systems, e.g. in combination with a transformer and an air speed sensor

Electrical connection and installation

Connection to 230V, 50/60Hz. The control module can be installed in a control cabinet door. Admissible relative humidity: 85%, noncondensing. Power supply for the sensors included:

+24V, 20%, I_{max} = 70mA.

Setting options

- Set values in the measurement range of the sensor (m/s, hPa = mbar), or in the volume flow range of the fan (×100m³/h)
- Switch over of set value (day/night)
- Min./max. setting range
- Translation of performance curve (P component)
- Constant of integration can be selected (I component)
- Reversal of the effect of the control behaviour
- Rotation of the performance curve
- Switchover or programming of internal/external set value
- Sensor selection via keypad
- Programming for "Filter fault"
- Keypad code
- K factor entry (The K10-factor can be found in the current lists of our fan line)

Technical Data

	Input voltage V	Output voltage V	Max. output current mA	Motor protection class	Operating consumption VA	Operating temperature °C
ERA 02- 4000-5E	0/10	0/10	10	IP20	10	+0/+40

Accessories

Universal control device



Dimensions in mm, subject to change.

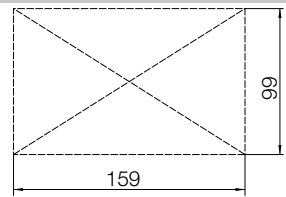
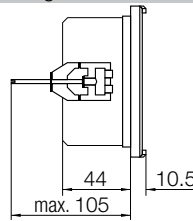
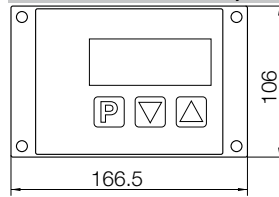

Instrument panel window

Wiring Diagram

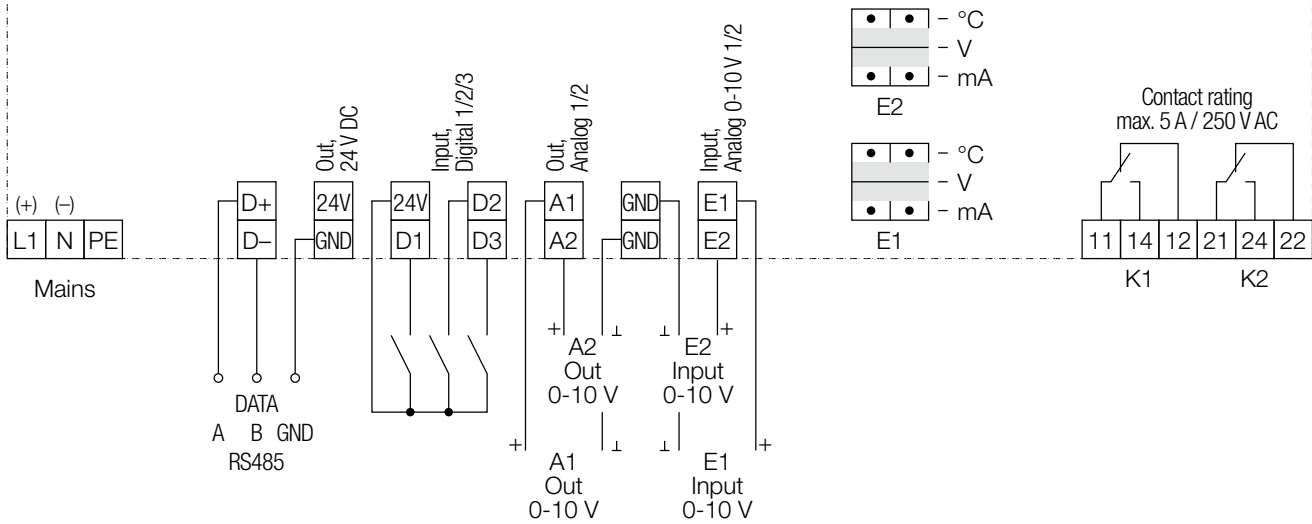

Differential pressure sensor



Differential pressure sensor with membrane for measuring the pressure, negative pressure or differential pressure of nonaggressive gases.

Type

The differential pressure to be measured acts transformed into an output signal of 0...10V by electronics (in SMD technology).

Application ranges

Volume flow regulators in centrifugal fans (with volume flow measuring device IMV) in connection with a frequency inverter type G110, MM420, MM430, or a universal regulator appliance type ERA 02-4000-5E in connection with a frequency regulator.

Electrical connection and installation

The differential pressure sensor delivers a starting signal (0...10V) by pressure increase at the "Plus" connection opposite pressure on the "Minus" connection.

Voltage supply

- 15...30V DC or 24V AC, 15%
- Pressure connections must point downward, tube connection ø5mm

Measuring accuracy

- Null drift: 0.75%
- Sum of linearity and hysteresis: 1%
- Temperature drift zero point: 0.3%/10K
- Temperature drift length of measurement: 0.2%/10K

Dimensions in mm, subject to change.

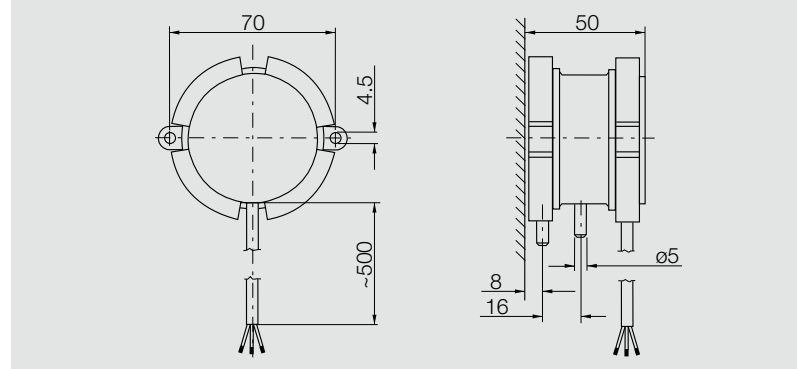

Technical Data

EIP 01-	Pressure range Pa	Motor protection class	Max. current consumption mA	Overload protection Pa	Output signal proportional V	Operating temperature °C
0200-12	+0/+200	IP65	12	20000	+0/+10	+0/+50
0500-12	+0/+500	IP65	12	20000	+0/+10	+0/+50
1000-12	+0/+1000	IP65	12	20000	+0/+10	+0/+50
2000-12	+0/+2000	IP65	12	20000	+0/+10	+0/+50
4000-12	+0/+4000	IP65	12	20000	+0/+10	+0/+50

Wiring Diagram

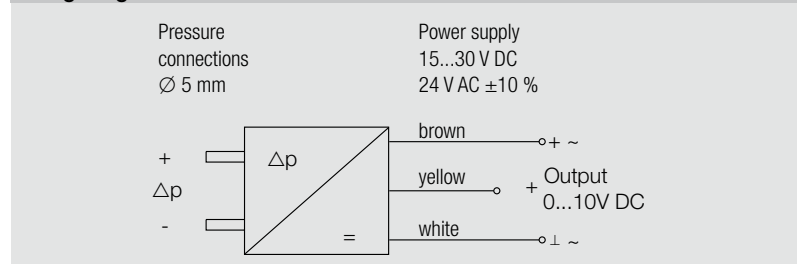

Accessories

Isolator ESH 21



Isolator ESH 21 (≤ 3kW)



Isolator ESH 21 (≥ 5.5kW)

Design

Beautifully shaped, shock-resistant plastic casing. Protection class IP44/IP65, for sur-face mounting, switching symbols 0 and I. The isolator is fitted with connection terminals that are very accessible and has a con-nection diagram glued in the casing.

The **ESH21 up to 3kW** is designed to IP44. It is equipped with an integrated lo-cking mechanism.

The **ESH21 up to 5.5kW** is designed to IP65. It is equipped with a coupling cover and an integrated locking mechanism. A padlock can in some cases be fitted to the rotary switch.

Function

The isolator disconnects the fan safely from the mains in the event of cleaning, maintenance or repair work on site and thus avoids accidents due to uncontrolled activation of the unit by third parties. It is no main switch or emergency switch.

All of the classified isolators are fitted with potential-free contacts (1 closer and 1 opener).

The isolators for motors with a built-in thermal contact have on principle three supplementary auxiliary contacts, so that the pre-switched control device does not drop out during cleaning or servicing work due to motor.

Caution about combination with frequency inverter!

Special EMC-action can be necessary, furthermore do not switch during operation, overvoltages can destroy the switch and the motor-winding.

The isolators are grouped according to motor rated power. All important characteristic data are evident from the model designation.

E.g.: **ESH 21-0030-65** = 3kW switch - 6 main contacts - 5 auxiliary contacts

Technical Data | Dimensions

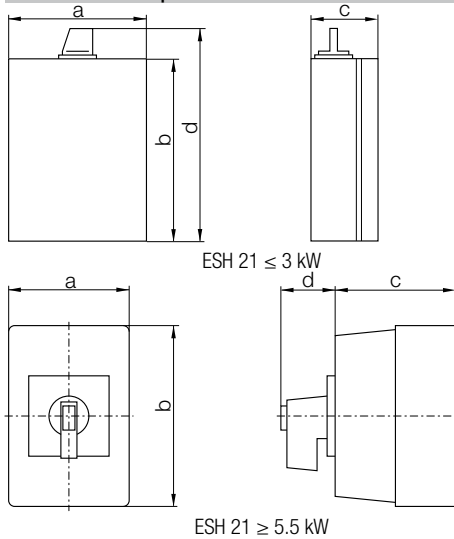

ESH 21-	Permissible motor power kW	a mm	b mm	c mm	d
0030-22	3	73	108	45	
0030-25	3	73	108	45	
0030-32	3	73	108	45	
0030-35	3	73	108	45	
0030-62	3	73	108	45	
0030-65	3	73	108	45	
0055-32	5.5	85	120	80	110
0055-65	5.5	125	125	126	157
0075-32	7.5	85	120	80	110
0075-35	7.5	85	120	80	110
0075-62	7.5	100	190	91	133
0075-95	7.5	125	125	126	157
0110-32	11	85	160	80	110
0110-62	11	100	190	91	133
0150-32	15	100	190	91	120
0150-62	15	145	250	100	145
0220-32	22	100	190	91	120
0220-62	22	145	250	100	145
0300-32	30	145	250	100	140
0300-62	30	200	300	172	200
0370-32	37	145	250	100	140
0370-62	37	200	300	172	200
0450-32	45	200	300	172	200
0450-62	45	300	300	172	210
0550-32	55	200	300	172	200
0550-62	55	300	300	172	210
0900-32	90	280	400	180	210
0900-62	90	280	280	260	327

Accessories

Isolator ESH 22

Design

Shock-resistant metal casing, black switch with symbols 0 and I. Protection class IP65 or IP54, for surface mounting (see determination in the tabular).

The isolator is fitted with connection terminals that are very accessible and has a connection diagram glued in the casing.

All isolators are equipped with a coupling cover and an integrated locking mechanism. In some cases a padlock can be fitted to the rotary switch.

Function

The isolator disconnects the fan safely from the mains in the event of cleaning, maintenance or repair work on site and thus avoids accidents due to uncontrolled activation of the unit by third parties. It is no main switch or emergency switch.

All of the classified isolators are fitted with potential-free contacts (1 closer and 1 opener).

The isolators for motors with a built-in thermal contact have on principle three supplementary auxiliary contacts, so that the preswitched control device does not drop out during cleaning or servicing work due to motor.

Use

The isolator ESH22 with metal casing is necessary, if screened components must be used. (e.g. frequency inverters or control engineering devices are used featuring electronic components).

Attention!

Do not switch during operation, overvoltages can destroy the switch and the motor winding!

The isolators are grouped according to motor rated power. All important characteristic data are evident from the model designation.

E.g.: **ESH 22-0075-65** = 7.5kW switch, 6 main contacts, 5 auxiliary contacts.

Technical Data | Dimensions

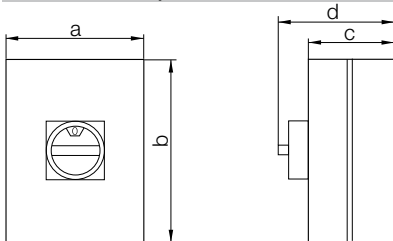

ESH 22-	Permissible motor power kW	a mm	b mm	c mm	d mm	Cable lead-through (top)	Cable lead-through (bottom)
0075-32	7.5	122	120	120	120	2×PG21	2×PG21
0110-32	11	122	120	120	120	2×PG21	2×PG21
0150-32	15	180	180	130	130	2×PG21	2×PG21
0220-32	22	180	180	130	130	2×PG21	2×PG21
0300-32	30	230	280	150	150	2×PG29/1×PG16	2×PG29
0370-32	37	230	280	150	150	2×PG36/1×PG16	2×PG36
0075-62	7.5	180	180	130	130	1×PG29/1×PG16	2×PG29
0110-62	11	180	180	130	130	1×PG36/1×PG16	2×PG36
0150-62	15	230	280	150	150	2×PG36/1×PG16	2×PG36
0220-62	22	230	280	150	150	2×PG36/1×PG16	2×PG36
0300-62	30	230	280	150	150	2×PG36/1×PG16	2×PG36
0370-62	37	230	280	150	150	2×PG36/1×PG16	2×PG36
0055-35	5.5	180	180	100	100	2×PG21	2×PG21
0075-65	7.5	116	95	80	80	2×PG16	2×PG16
0075-95	7.5	116	95	80	80	2×PG16	2×PG16

Notes

Quality management system

DIN EN ISO 9001

Nicotra Gebhardt quality is the result of a continuous company policy intended to guarantee that our product properties and features are clearly superior to comparable products.

This already established company maxim led in April 1985 to the auditing and certification of the existing quality management system. In the following years it was updated to match the changing international and European standards. Modern production processes, monitored by our quality management system, guarantee a high repeat accuracy in production.

This ongoing high standard of quality permits the establishing of the performance data in classes of accuracy in accordance with DIN 24166.

The narrow tolerances ensure a high level of data reliability for our products.

Machine Safety

The fans contained in this catalogue are not machines in the sense of the EC Machine Directive. They are delivered with a manufacturer "Declaration of incorporation".

The assessment of the dangers associated with the fan and necessary safety measures are based on the VDMA Unit sheet 24167 : Fans; Safety requirements.

The operating instructions give which safety measures are still necessary on assembly to ensure that the fans comply with the Machine Directive 2006/42/EC.

Catalogue data

We reserve the right to change any measurements and technical data in this catalogue in accordance with further development of our products. All information valid at the time of printing.

